

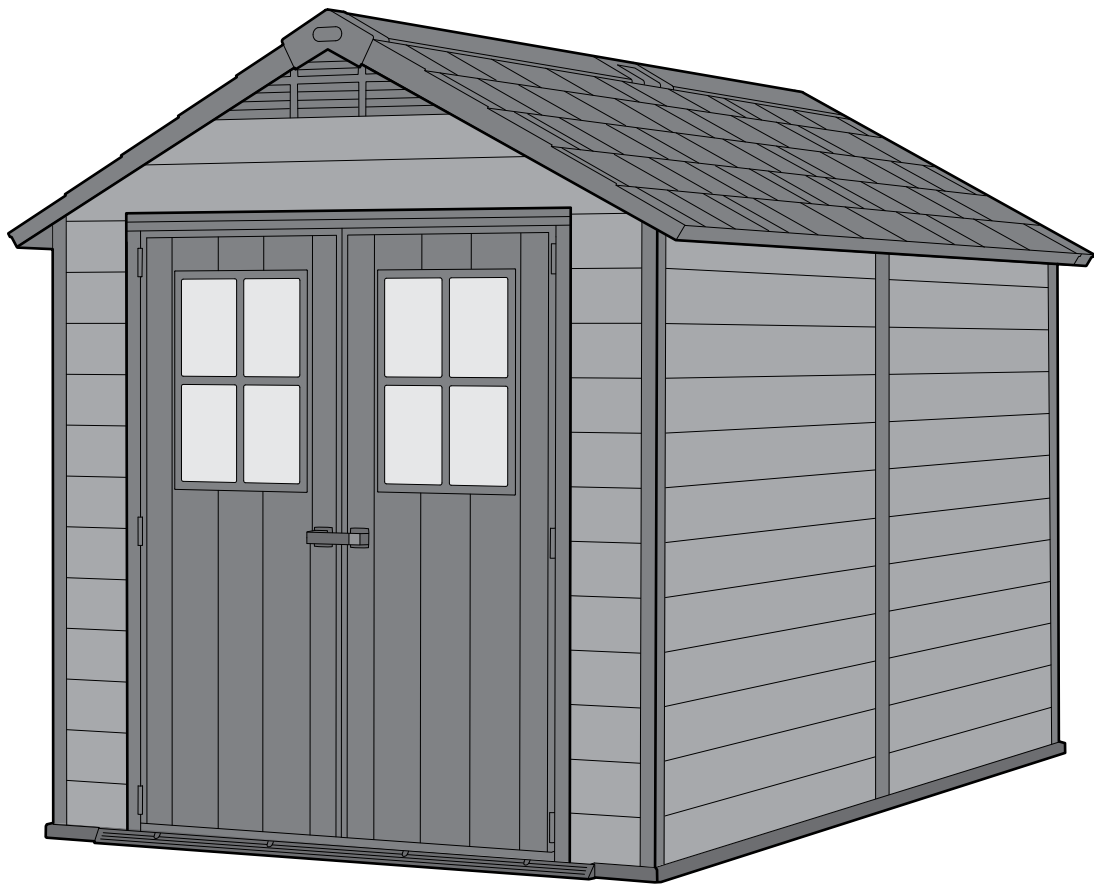

NEWTON 759

USER MANUAL | MODE D'EMPLOI | MANUAL DEL USUARIO | GEBRAUCHSANLEITUNG |
GEBRUIKSHANDLEIDING | MANUALE PER L'UTENTE | MANUAL DO UTILIZADOR



A-1794 596088

SKU: 17208504

	<p>US, Canada: Tel: +1-877-638-7056 Fax: +1-704-263-9271 UK: Tel: +44-121-506-0008 Fax: +44-121-422-0808 Spain: Tlf: +34-976-46-00-06 Fax: +34-976-460-281 Other European Countries: Tel: +31 (0) 161 22 8300</p>	
--	---	--

WARRANTY ACTIVATION Thank you for your purchase of the Keter shed. In order to activate your warranty, please log onto our website and fill in the form under warranty activation.

SITE PREPARATION | PRÉPARATION DU SITE | PREPARACIÓN DEL LUGAR | VORBEREITUNG DES AUFSTELLUNGORTES | VOORBEREIDING VAN HET TERREIN | PREPARAZIONE DEL LUOGO DI MONTAGGIO | PREPARAÇÃO DO LOCAL

Level the ground surface | Égalisez la surface du sol | Nivela la superficie del suelo | Ebenen Sie die Bodenoberfläche | Maak de bodem vlak | Livella la superficie del terreno | Nivela a superfície do solo

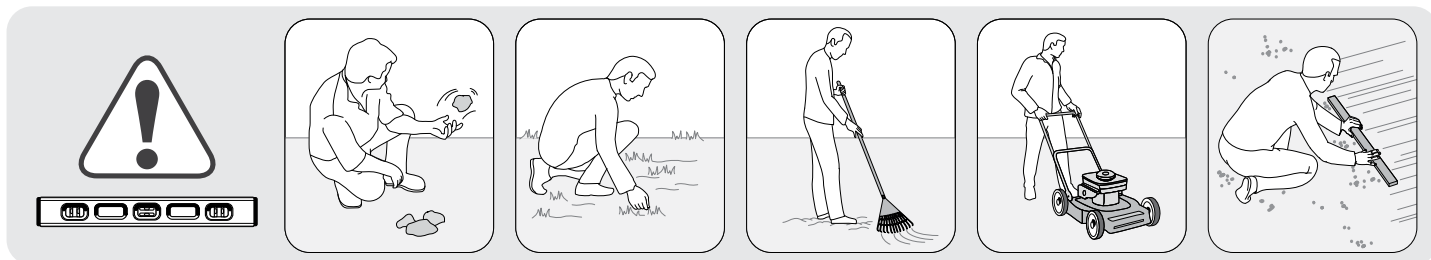

Recommendation: Construct a wooden or concrete base as a foundation | **Recommandation:** fabriquez une base en bois ou en béton en guise de fondation | **Recomendación:** construya una base de madera o de cemento a modo de cimiento | **Empfehlung:** Bauen Sie als Fundament eine Grundfläche aus Holz oder Beton | **Aanbeveling:** maak een houten of betonnen ondergrond als fundering | **Raccomandazione:** costruisci una base di legno o di cemento come fondamenta | **Recomendação:** Construa uma base de madeira ou de cimento como fundação

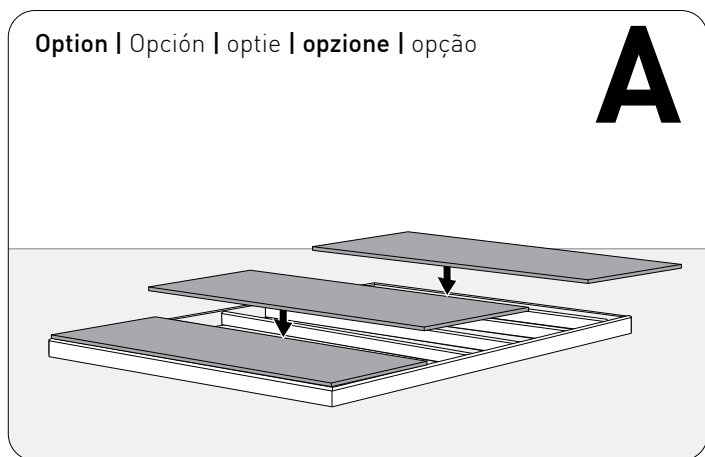

For external access during assembly, make sure to leave enough room around the outside of the shed assembly site.

Pour un accès externe au cours du montage, veillez à laisser suffisamment de place autour du site de montage.

Para tener un acceso exterior durante el montaje, asegúrese de dejar suficiente espacio alrededor del lugar de montaje del cobertizo.

Lassen Sie am Aufstellungsort außerhalb des Schuppens ausreichend Platz, so dass Sie während des Aufbaus von außen Zugang zum Schuppen haben.

Om tijdens de montage aan de buitenkant van het schuurtje te kunnen werken, moet u ervoor zorgen dat u genoeg ruimte laat aan de buitenkant van de montageplaats.

Per l'accesso esterno durante il montaggio, assicurati di lasciare abbastanza spazio intorno alla parte esterna del luogo di montaggio del deposito attrezzi.

Para ter acesso externo durante a montagem certifique-se de que deixa espaço suficiente em redor do exterior do local de montagem do abrigo.

External floor measurements are: | Les mesures externes de la étage sont: | Las medidas del suelo externo son: | Die Außen-Bodenmaße betragen: | De afmetingen van de externe vloer zijn: | Le mesure del pavimento esterno sono: | As medidas externas do chão são:

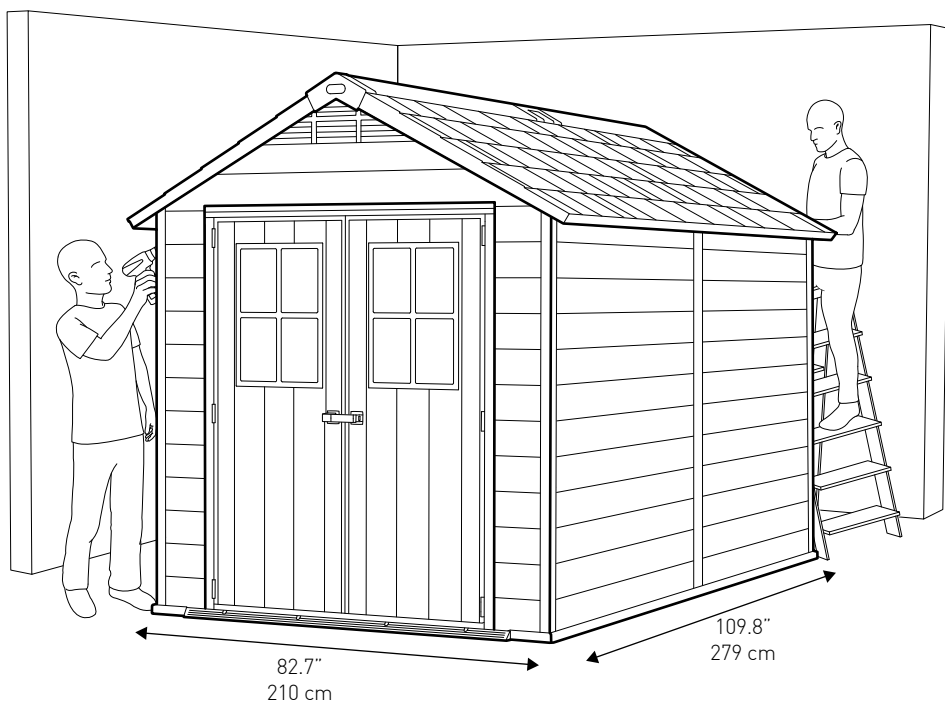

BEFORE STARTING ASSEMBLY | AVANT DE COMMENCER LE MONTAGE | ANTES DE EMPEZAR EL ARMADO | VOR MONTAGEBEGINN | VOORDAT U BEGINT TE MONTEREN | PRIMA DI INIZIARE IL MONTAGGIO | ANTES DE INICIAR A MONTAGEM

Read the care and safety guidelines at the end of this manual | Check to ensure that there are no missing or damaged parts BEFORE starting or arranging assembly | Review all assembly instructions | Assemble all the parts according to the directions in this manual. Do not skip any steps.

Lisez les instructions de précaution et de sécurité à la fin de ce manuel | Assurez-vous qu'il n'y a pas de pièces manquantes ou endommagées AVANT de commencer ou d'organiser l'assemblage | Lisez toutes les instructions de montage | Assemblez toutes les pièces selon les instructions de ce manuel. Ne sautez aucune étape.

Lea las instrucciones de precauciones y seguridad que están al final de este manual | Asegúrese de que no faltan piezas ni están dañadas ANTES de comenzar o disponer el montaje | Revise todas las instrucciones de montaje | Monte todas las piezas según las instrucciones de este manual. No se saltee ningún paso.

Lesen Sie die Sicherheitsrichtlinien am Ende des Benutzerhandbuchs durch | Prüfen Sie bitte VOR dem Zusammenbau, dass keine Teile beschädigt sind oder fehlen | Gehen Sie noch einmal die komplette Aufbauanleitung durch | Bauen Sie alle Teile entsprechend der Anleitung in diesem Handbuch zusammen. Lassen Sie dabei keinen Arbeitsschritt aus.

Lees de richtlijnen voor zorg en veiligheid achterin deze handleiding | Controleer dat er geen onderdelen mankeren, of beschadigd zijn, VOORDAT u met de montage begint | Bekijk alle montagehandleidingen | Monteer alle onderdelen volgens de aanwijzingen van deze handleiding. Sla geen stappen over.

Leggi le linee guida di assistenza e sicurezza alla fine di questo manuale | Verificare per assicurarsi che non ci siano parti mancanti o danneggiate PRIMA di iniziare o di disporre il montaggio | Consulta tutte le istruzioni di montaggio | Monta tutti i componenti secondo le istruzioni contenute in questo manuale. Non saltare nessuna fase.

Leia as diretrizes de cuidados e segurança que constam da parte final deste manual | Verifique para se assegurar de que não há peças em falta ou danificadas ANTES de começar a preparar a montagem | Reveja todas as instruções de montagem | Monte todas as peças de acordo com as instruções do manual. Não salte quaisquer passos.

REQUIRED TOOLS | OUTILS EXIGÉS | HERRAMIENTAS NECESARIAS | BENÖTIGTE WERKZEUGE | BENODIGD GEREEDSCHAP | ATTREZZATURA OCCORRENTE | FERRAMENTAS NECESSÁRIAS

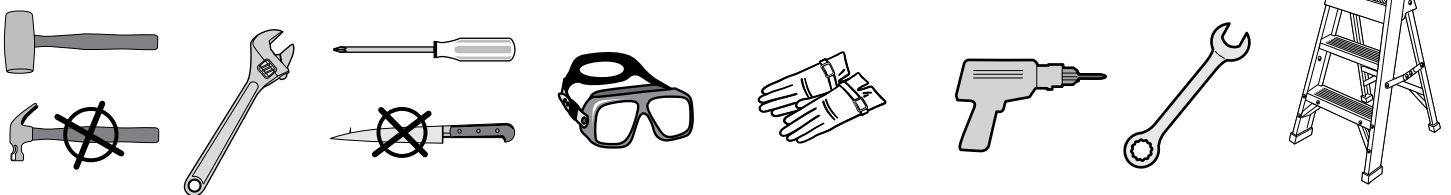

SPATULA | SPATULE | ESPÁTULA | SPACHTEL | SPATEL | SPATOLA | ESPÁTULA

- Use spatula (part "SPA") for easier insertion of panel into profile.
- Utilisez la spatule (partie "SPA") pour une meilleure insertion du panneau dans le profil.
- Utilice una espátula (pieza "SPA") para una mejor inserción del panel en el perfil.
- Benutzen Sie den Spachtel (Bezeichnung „SPA“), um die Platten leichter in die Nut einführen zu können.
- Gebruik spatel (onderdeel SPA) voor het gemakkelijk invoeren van het paneel in het profiel.
- Utilizzare la spatola (parte SPA) per inserire il pannello più facilmente nel profilo.
- Utilize uma espátula (peça "SPA") para facilitar a inserção do painel no perfil.

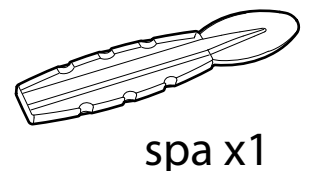

ASSEMBLY REQUIRES TWO PEOPLE | LE MONTAGE DOIT ÊTRE EFFECTUÉ PAR DEUX PERSONNES | SE NECESITAN DOS PERSONAS PARA ARMARLO | ZWEI PERSONEN ZUR MONTAGE NOTWENDIG | MONTAGE VEREIST TWEEL PERSONEN | MONTAGGIO RICHIEDE DUE PERSONE | A MONTAGEM EXIGE DUAS PESSOAS

SHED PARTS | PIÈCES DE L'ABRI | PARTES DEL COBERTIZO | TEILE DES SCHUPPENS | ONDERDELEN VAN HET SCHUURTJE | COMPONENTI DEL DEPOSITO ATTREZZI | PEÇAS DO ABRIGO

Remove all parts from the package(s) and spread them out on a clean work surface | Code letters are imprinted on each part for easy identification | Retirez toutes les pièces du/des paquet(s) et étalez-les sur une surface de travail propre | Des lettres sont imprimées sur chaque pièce pour une identification facile | Saque todas las piezas del paquete o paquetes y póngalas sobre una superficie de trabajo limpia | El código de letras está marcado en cada pieza para que sea más fácil identificarla | Nehmen Sie alle Teile aus der Verpackung und breiten Sie sie auf einer sauberen Arbeitsfläche aus | Auf jedem Teil sind Kennbuchstaben aufgedruckt, die die Zuordnung der einzelnen Teile erleichtern | Haal alle onderdelen uit het pakket (of uit de pakketten) en leg ze op een schoon werkoppervlak | Op ieder onderdeel zijn codes aangebracht voor een gemakkelijke identificatie | Rimuovi tutti i componenti dal pacchetto (i) e spargili su una superficie di lavoro pulita | Le lettere del codice sono state stampate su ciascun componente per una facile identificazione | Retire todas as peças da embalagem e espalhe-as numa superfície de trabalho limpa | Existem letras de código impressas em cada peça para fácil identificação

FLOOR PARTS | ÉLÉMENTS DU PLANCHER | PARTES DEL SUELO | BODENTEILE | VLOERPANELEN | PARTI DEL PAVIMENTO | PEÇAS DO CHÃO

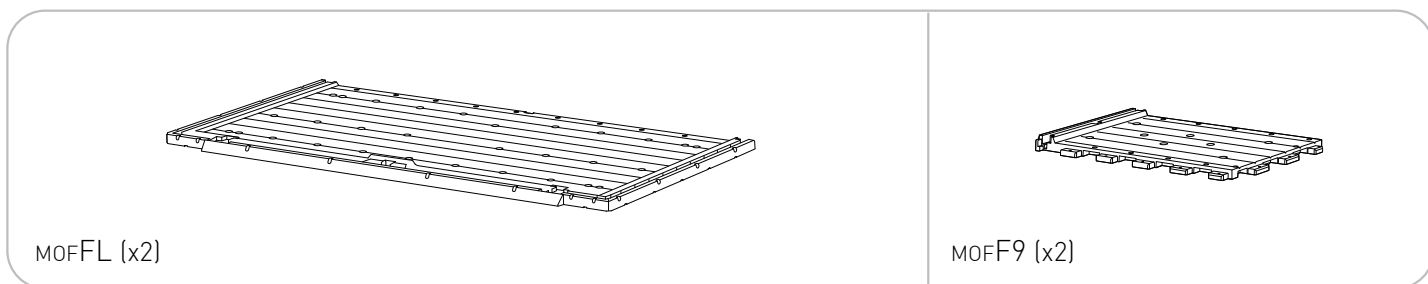

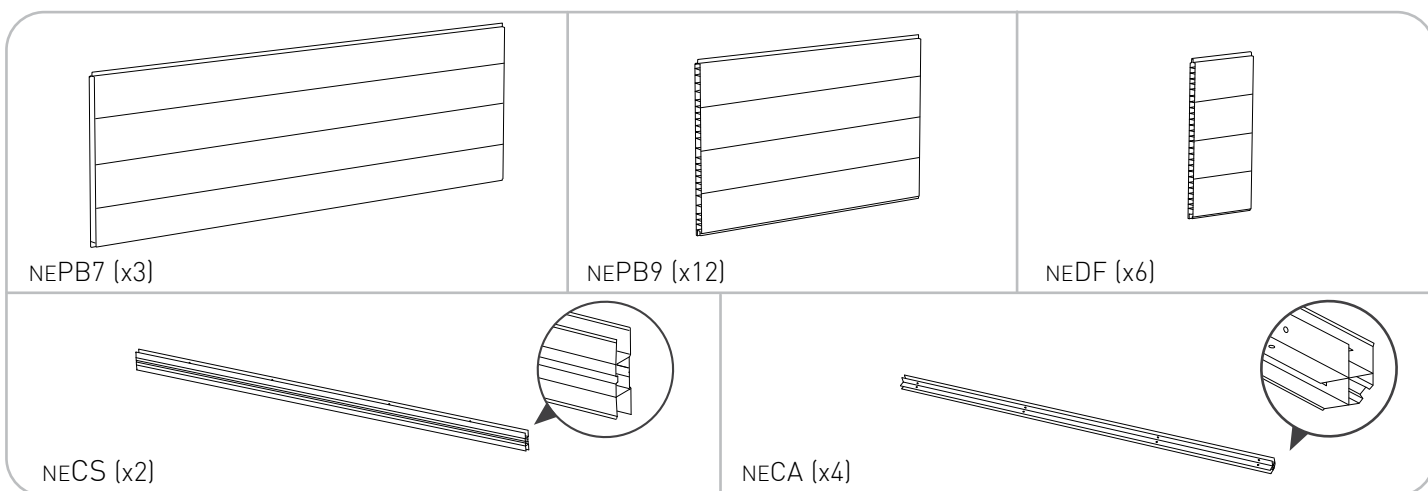

WALL PARTS | PIÈCES DU CONTOUR | PARTES DE LAS PAREDES | WANDELEMENTE | MUURONDERDELEN | PARTI DELLA PARETE | PAINÉIS LATERAIS



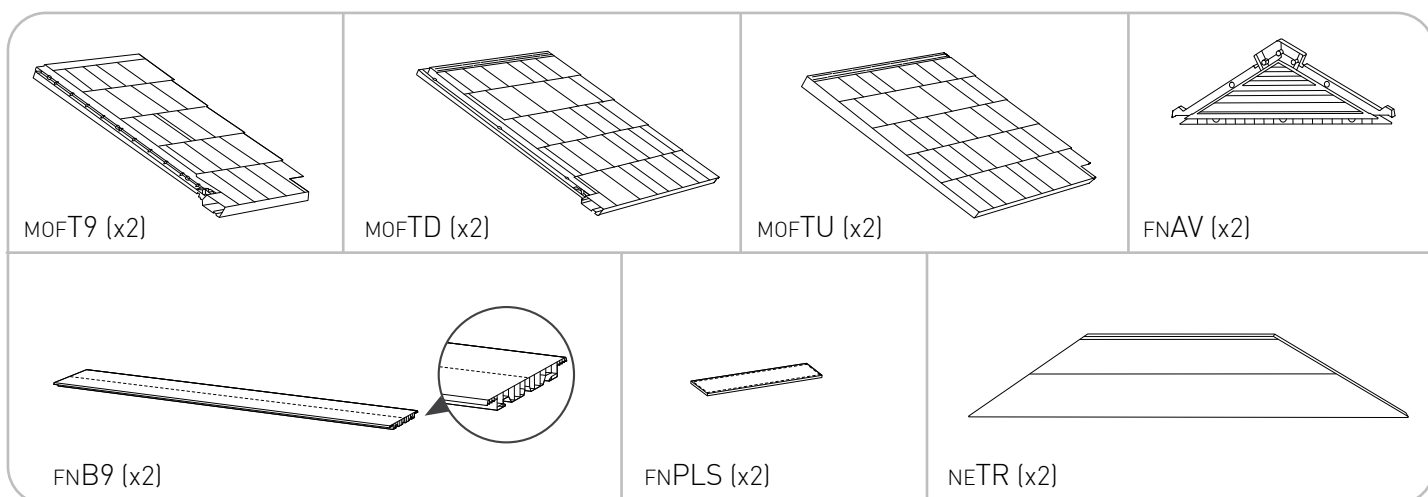



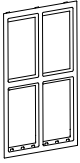
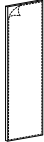

ROOF PARTS | PIÈCES DU TOIT | PARTES DEL TECHO | DACHELEMENTE | DAKONDERDELEN | PARTI DEL TETTO | PEÇAS DO TELHADO



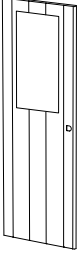
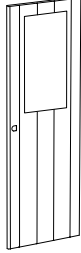
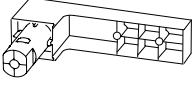
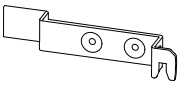



WINDOW PARTS | PIÈCES DE LA FENÊTRE | PARTES DE LA VENTANA | FENSTERELEMENTE | VENSTERONDERDELEN | PARTI DELLA FINESTRA | PEÇAS DA JANELA

 smWF (x2)	 smWG (x4)	 moWB (x2)
--	--	--



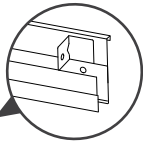
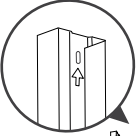
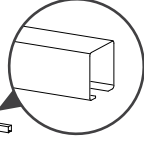
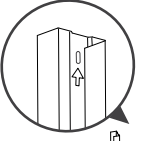

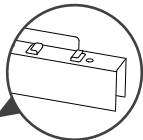
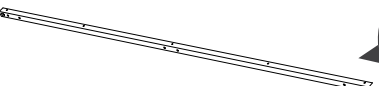
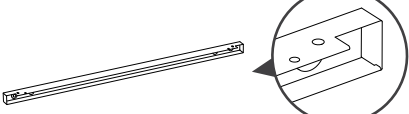
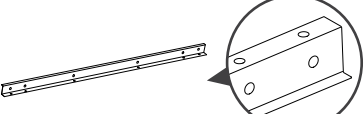
DOOR PARTS | PIÈCES DE LA PORTE | PARTES DE LA PUERTA | TÜRELEMENTE | DEURONDERDELEN | PARTI DELLA PORTA | PEÇAS DAS PORTAS

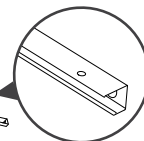
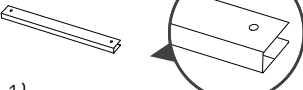
 neWDL (x1)	 neWDR (x1)	 NEHA (x1)	 FNH7 (x1)	
		 NEHE (x1)	 FNH6 (x1)	 NEHF (x1)
		 NEHB (x1)	 NEHC (x1)	 NEHG (x1)



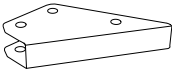
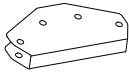

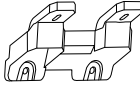
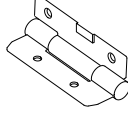
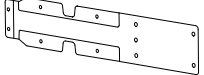
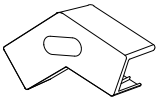
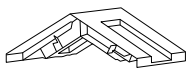
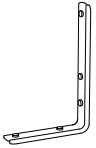
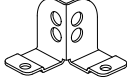
METAL PARTS | PIÈCES MÉTALLIQUES | PIEZAS METÁLICAS | METALLTEILE | METALEN DELEN | PARTI IN METALLO | PARTES METÁLICAS

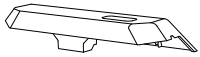
 NEUK (x1)	 NEFM (x1)	 NEHSC (x2)
 NELR (x2)	 NEDSO (x2)	
 NEMS (x2)	 NEDSI (x1)	
 NEMBA (x1)	 NEDSW (x1)	
 NEDC (x4)	 moFM7 (x4)	 moFM9 (x4)
 NEMB (x2)	 moSF (x2)	 FNMH (x1)

SMALL PARTS | PETITES PIÈCES | PARTES PEQUEÑAS | KLEINTEILE | KLEINE ONDERDELEN | MINUTERIA | PEÇAS PEQUENAS

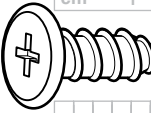
					
FNME (x2)	FNMA (x1)	FNTM (x4)	MoFTC (x4)	NEDH (x6)	NETPR (x2)
					
FNAC (x2)	FNBC9 (x1)	NEDMC (x8)	NEMBH (x2)	NEDPC (x2)	NEDT (x1)

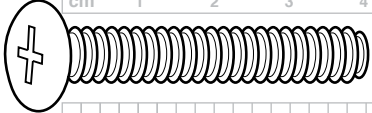
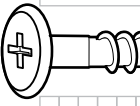
SCREWS | VIS | TORNILLOS | SCHRAUBEN | SCHROEVEN | VITI | PARAFUSOS

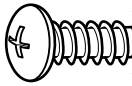
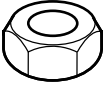
 cm 1 2 3 4 inch 0.5 1 1.5	 cm 1 2 3 4 inch 0.5 1 1.5	 cm 1 2 3 4 inch 0.5 1 1.5
sc15 (x244) 16 mm / 0.63"	S13b (x121) 12 mm / 0.47"	sc8 (x13) 43 mm / 1.69"
 cm 1 2 3 4 inch 0.5 1 1.5	 cm 1 2 3 4 inch 0.5 1 1.5	 cm 1 2 inch 0.5
s45b (x48) 45 mm / 1.77"	S26b (x8) 26 mm / 1"	sf13 (x16) 10 mm / 0.39"
		 scn8 (x13)

Packaging may contain some additional small parts for use as spare parts | L'emballage peut contenir de petites pièces supplémentaires à utiliser comme pièces de rechange | El envoltorio puede contener algunas piezas pequeñas adicionales que se pueden utilizar como repuestos | In der Verpackung können kleine Zusatzteile enthalten sein, die als Ersatzteile genutzt werden können | De verpakking kan een aantal kleine extra onderdelen bevatten, die als reserveonderdeel gebruikt kunnen worden | La confezione potrebbe contenere piccole parti supplementari da utilizzare come parti di ricambio | A embalagem pode conter algumas pequenas peças adicionais para utilização como peças de reposição

NOTE: Due to variations in production, the actual assembled size may vary slightly from the specified dimensions.

REMARQUE: En raison de variantes dans la production, la taille de montage réelle peut différer quelque peu des dimensions indiquées.

NOTA: debido a las variaciones en la producción, el tamaño real al montarlo puede variar ligeramente con respecto a las dimensiones especificadas.

BITTE BEACHTEN: Aufgrund von Abweichungen in der Herstellung kann die tatsächliche Größe leicht von den angegebenen Maßen abweichen.

LET OP: vanwege afwijkingen in de productie kan de werkelijke afmeting na montage een klein beetje afwijken van de opgegeven afmetingen.

NOTA: a causa di variazioni nella produzione, la dimensione effettiva del prodotto assemblato può variare leggermente dalle dimensioni menzionate.

NOTA: Devido a variações na produção o tamanho real da montagem poderá variar ligeiramente das dimensões especificadas.

1

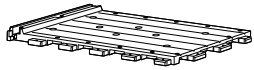

MOFF9 (x2)

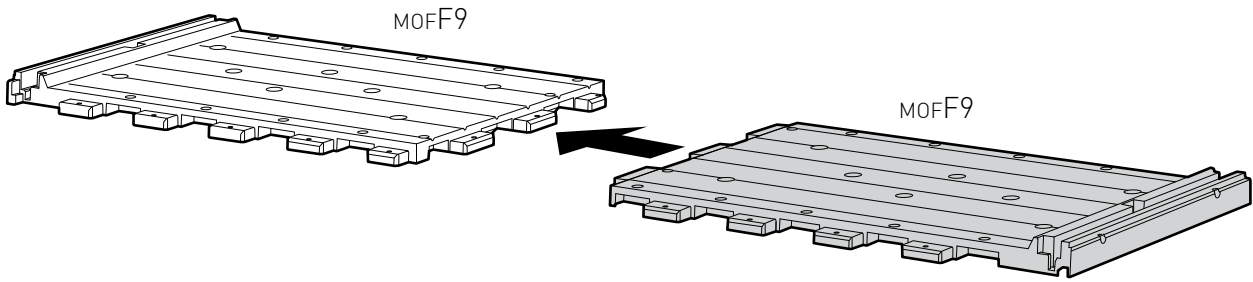
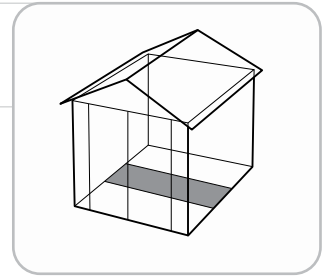

2



sc15 (x4)

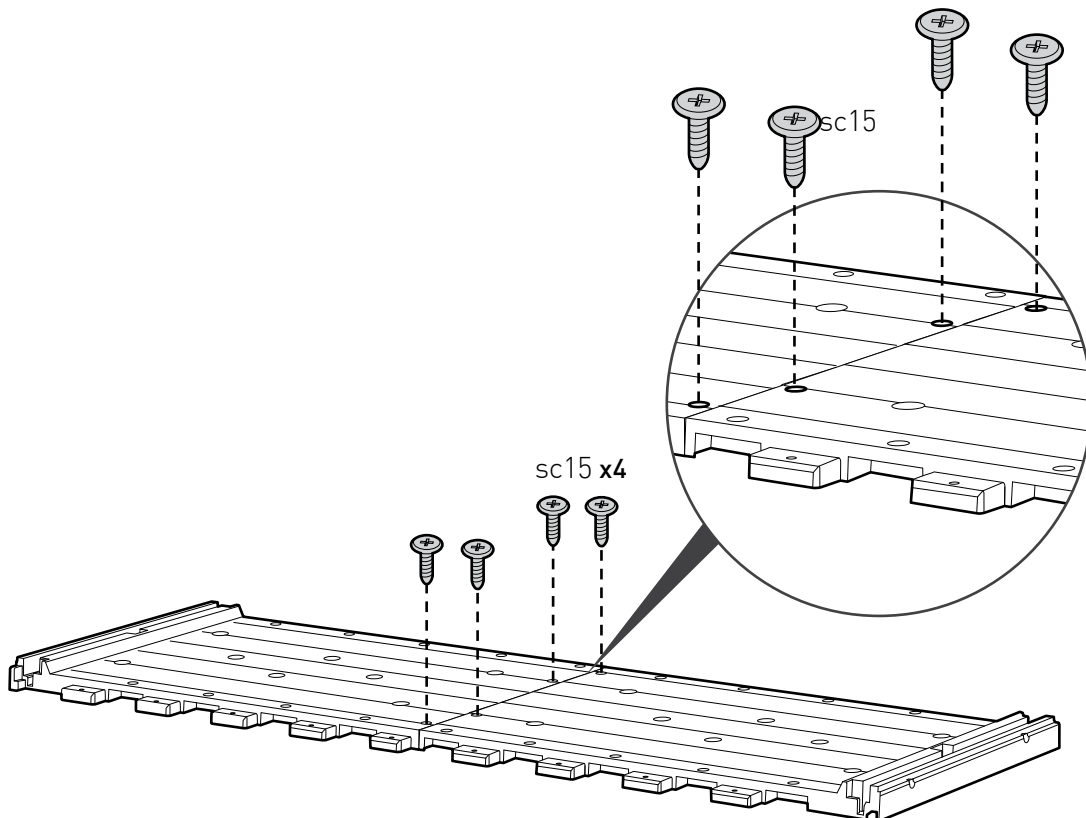
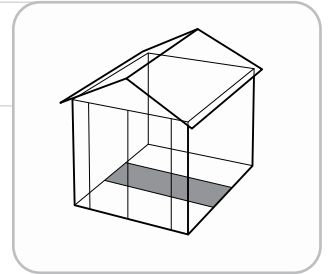

3

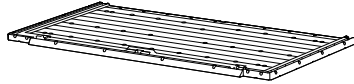
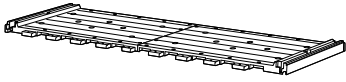

MOFFL (x2)

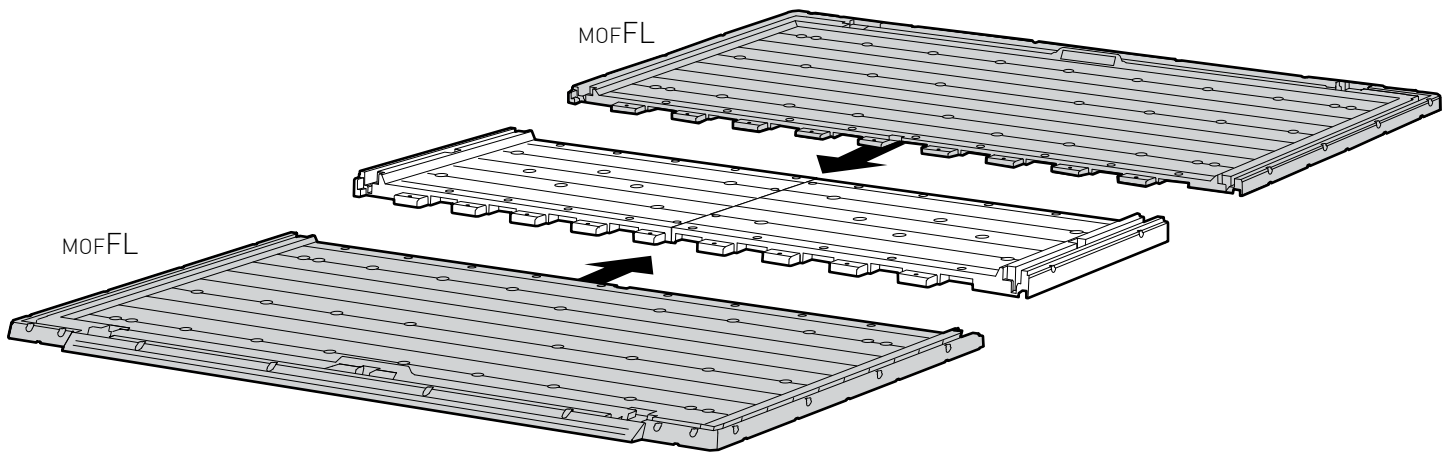
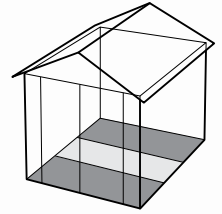

4

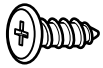

sc15 (x36)

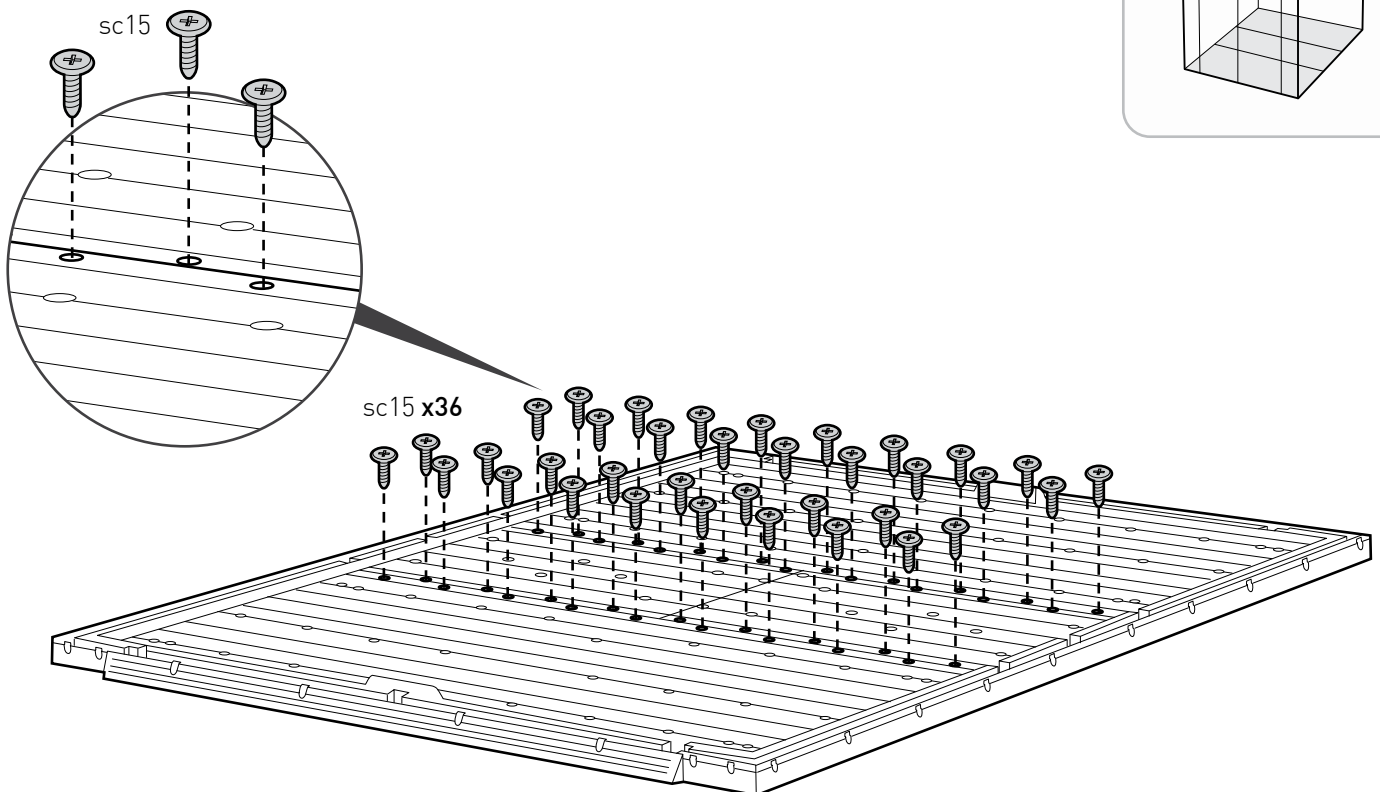
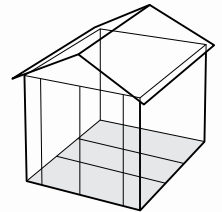

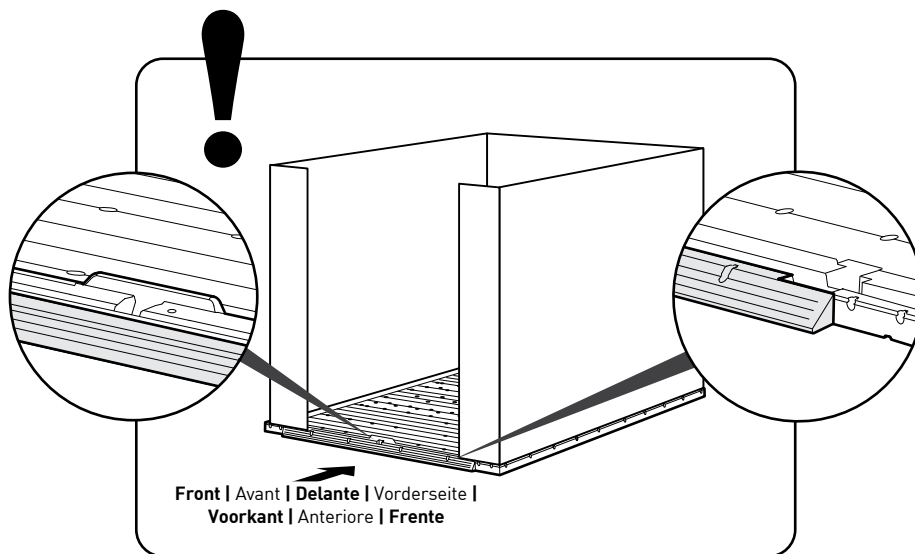

5



NE-DT (x1)



s26b (x2)

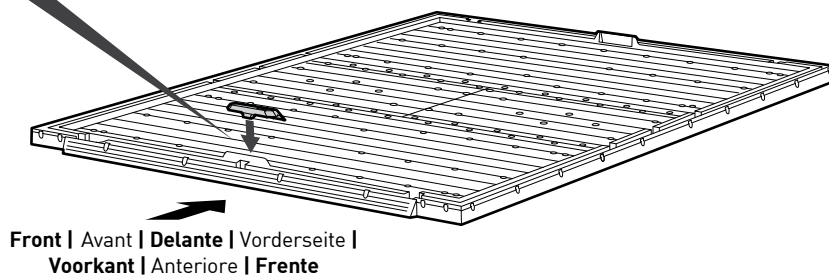
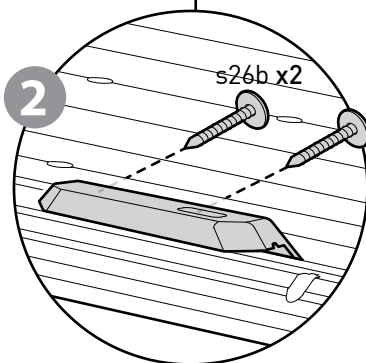
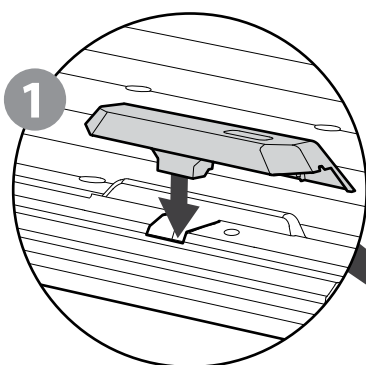
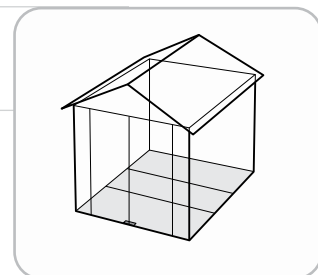

6

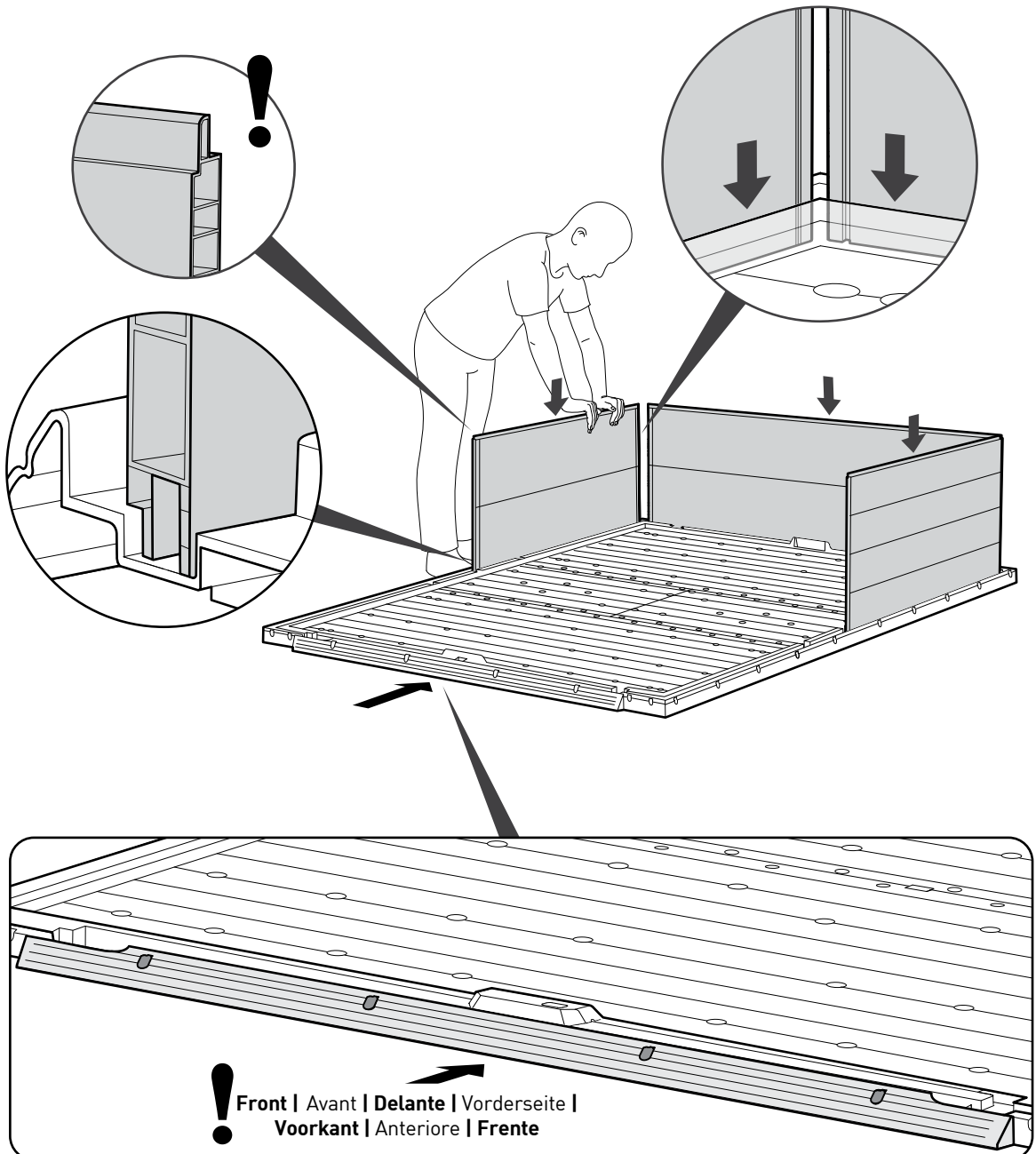
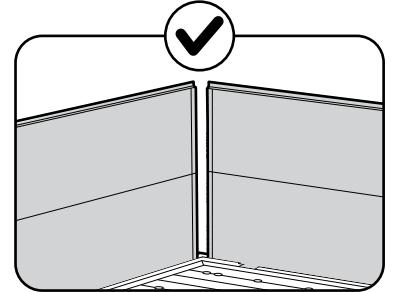
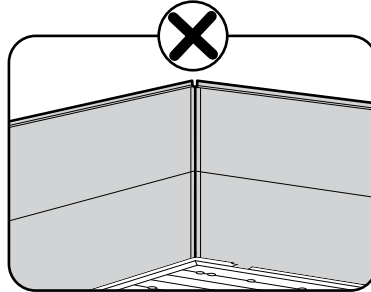
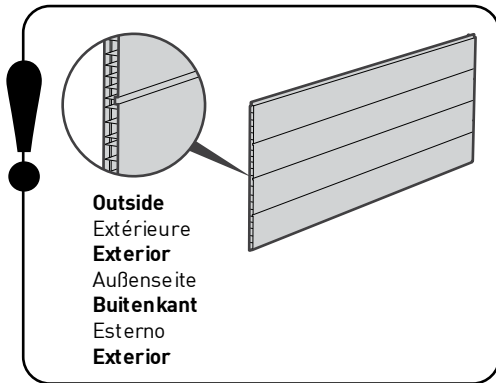
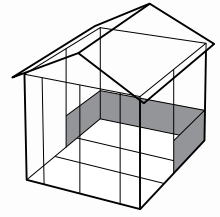

7

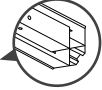
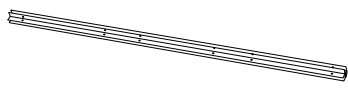

NECA (x2)

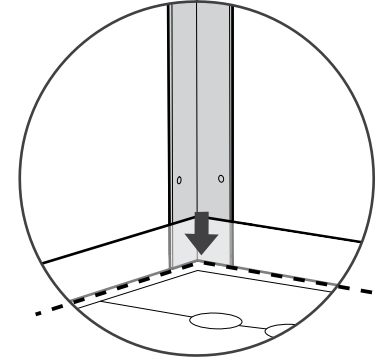
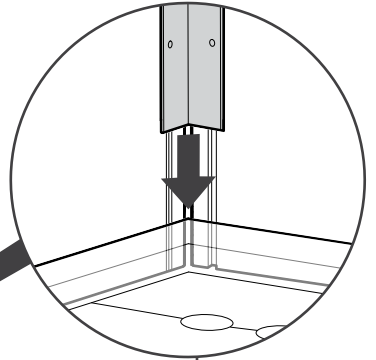
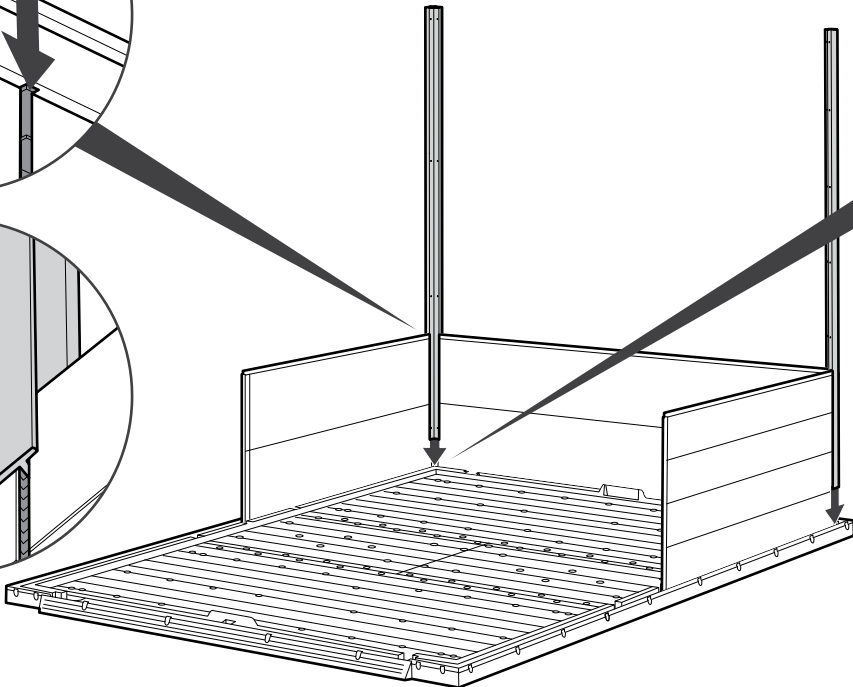
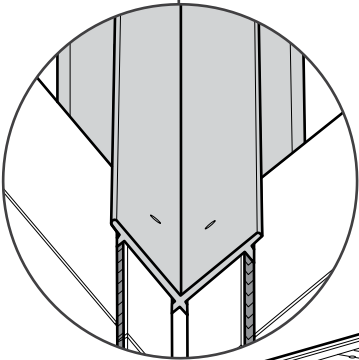
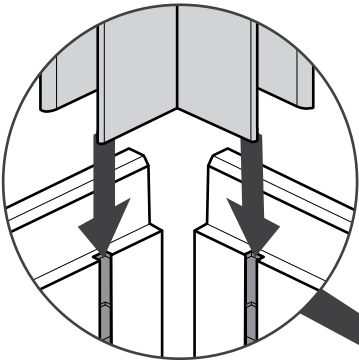
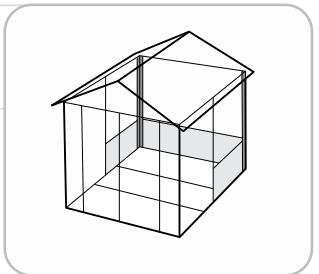

8

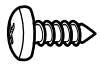

s13b (x4)

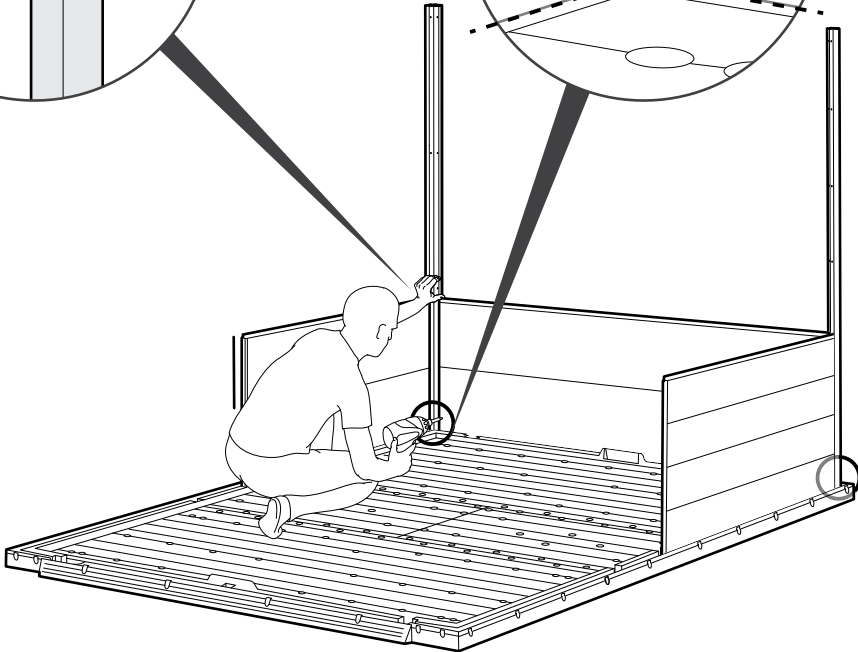
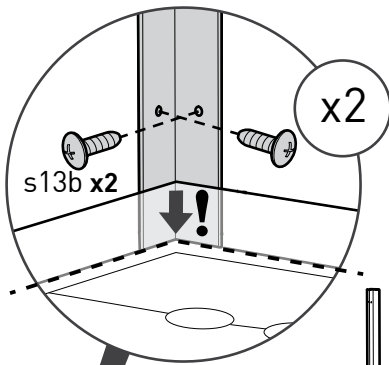
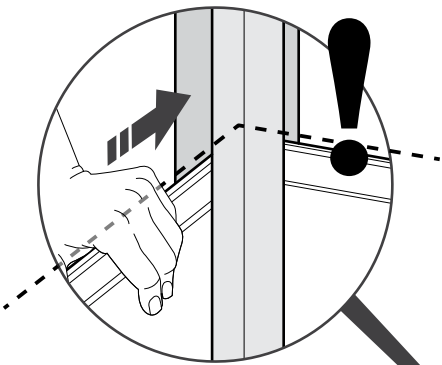
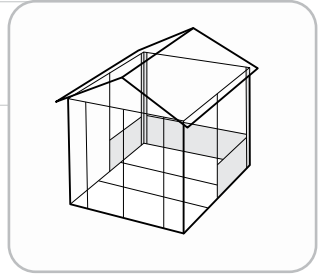

9

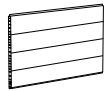

NEPB9 (x2)



NEPB7 (x1)

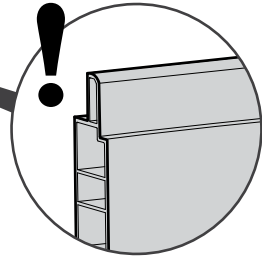
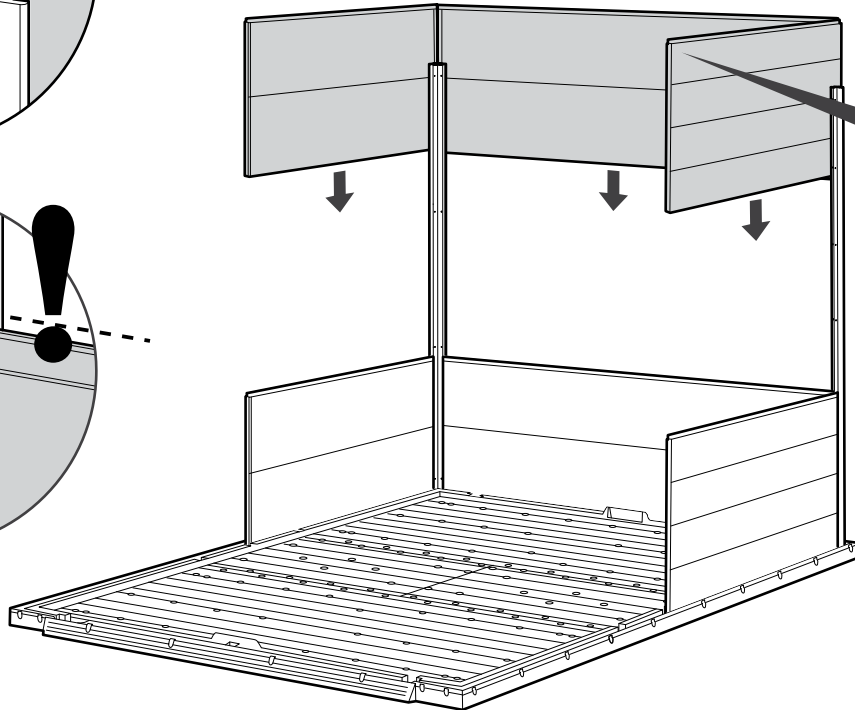
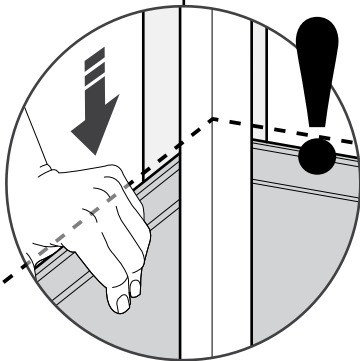
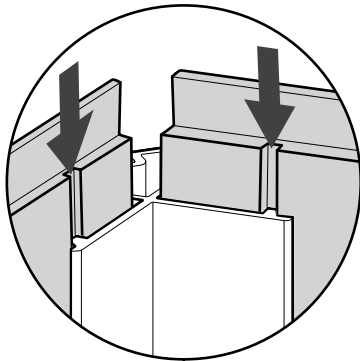
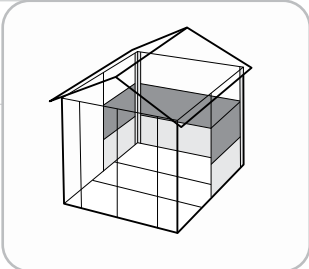

10



s13b (x4)

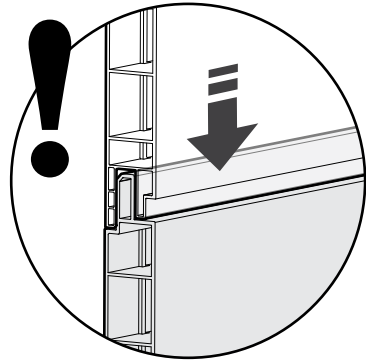
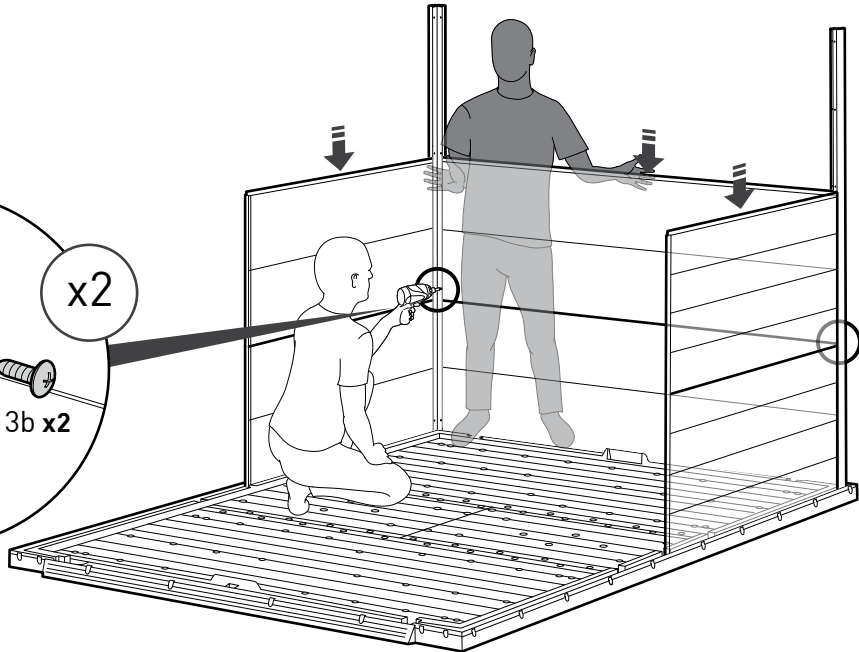
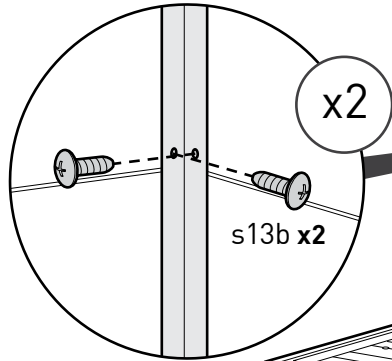
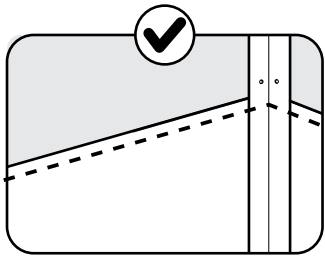
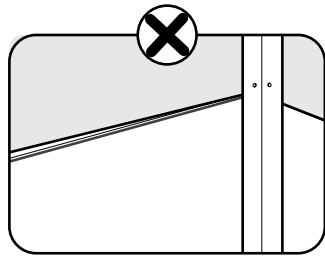
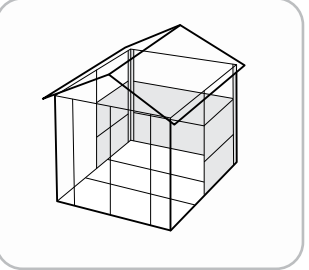

11

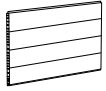

NEPB9 (x2)



NEPB7 (x1)

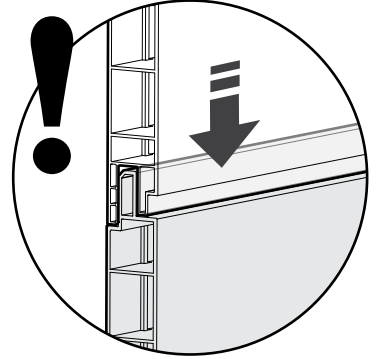
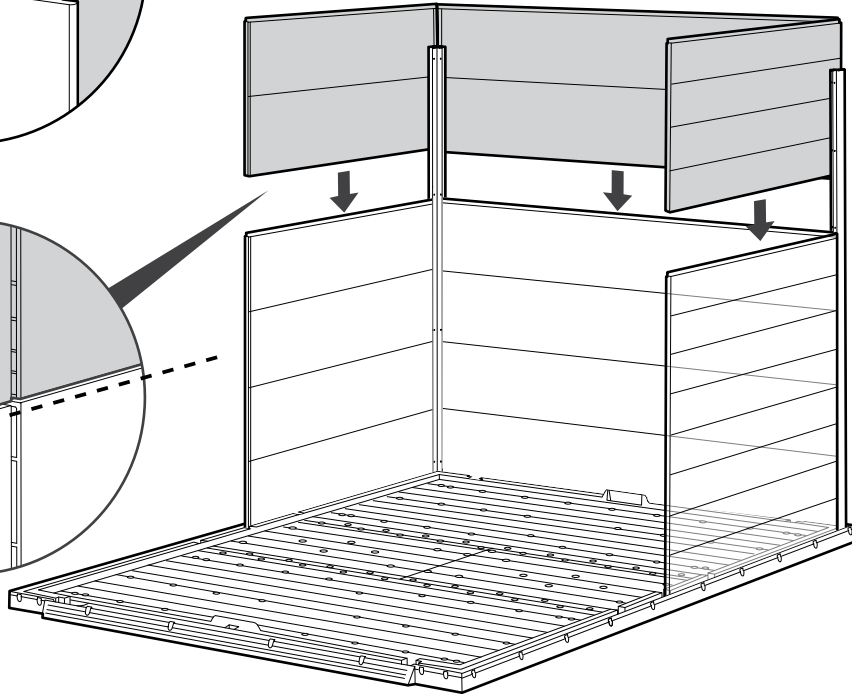
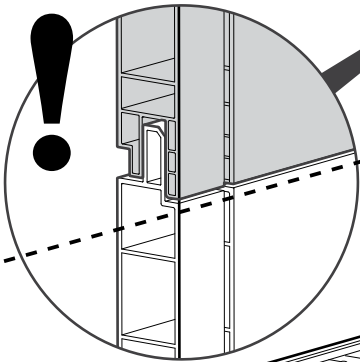
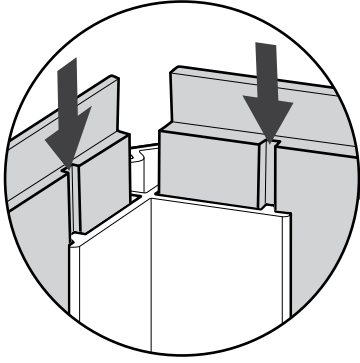
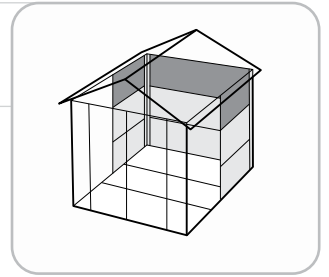

12



s13b (x8)

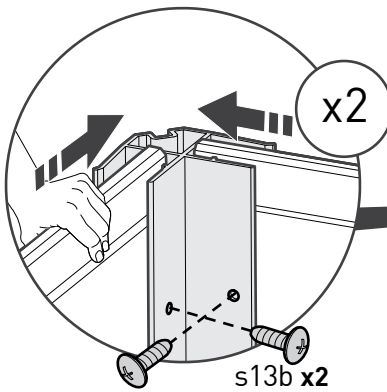
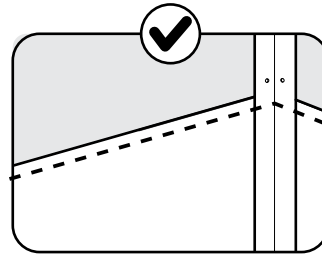
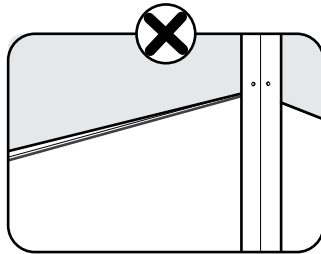
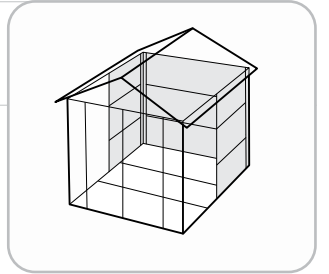

s13b x2

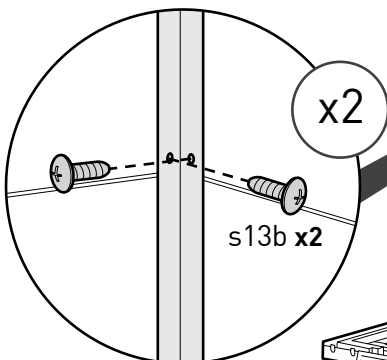

s13b x2

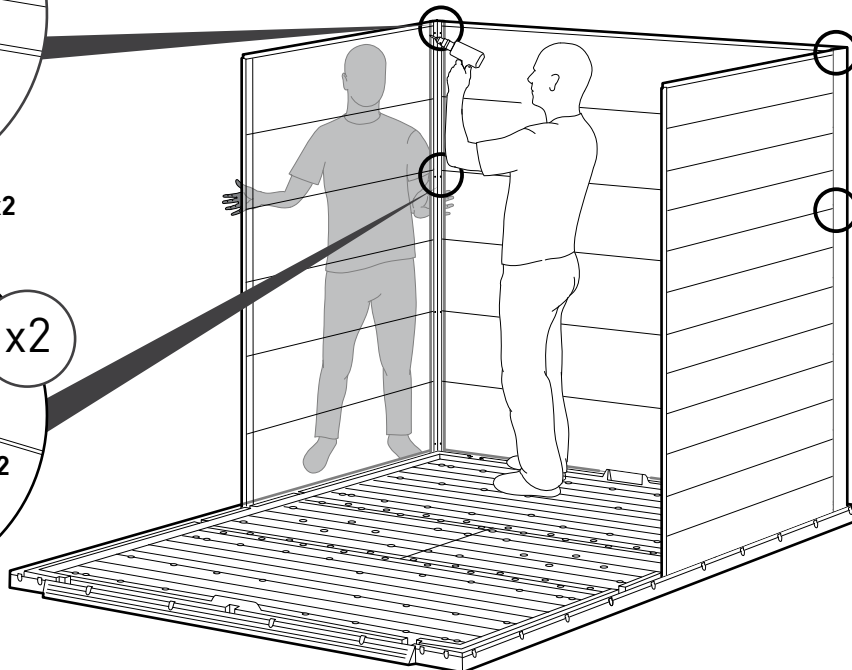

13



NECS (x1)

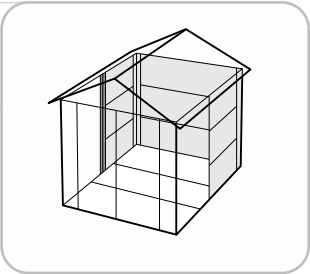

1

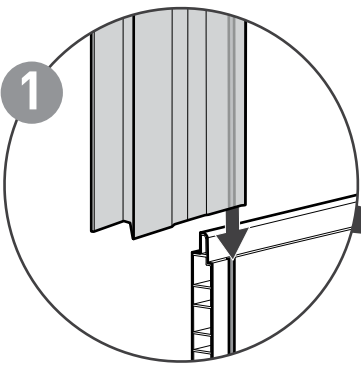

2

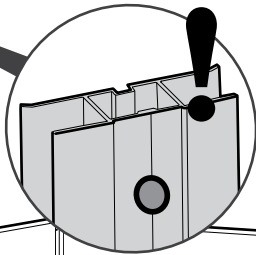
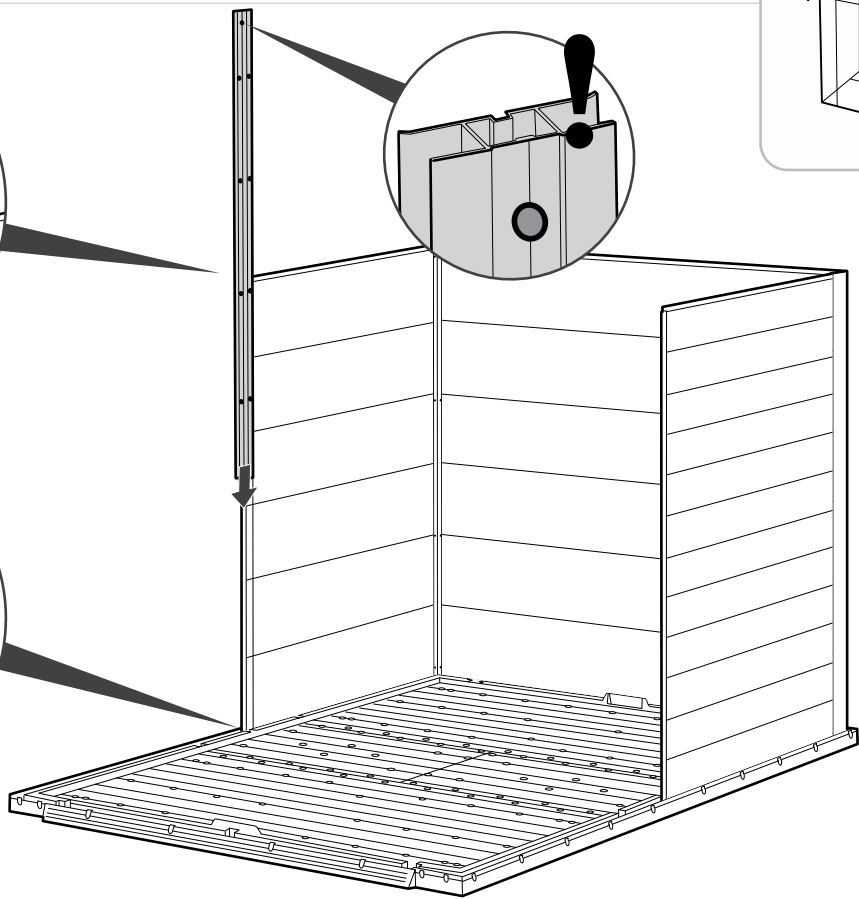
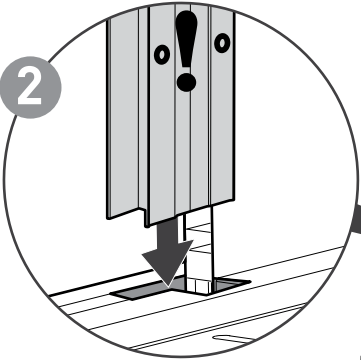

14



NECS (x1)

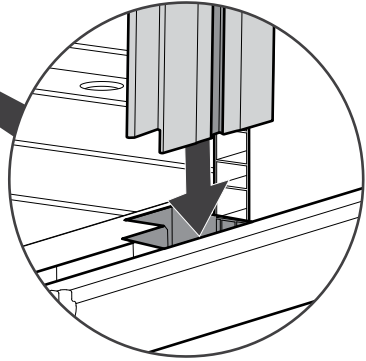
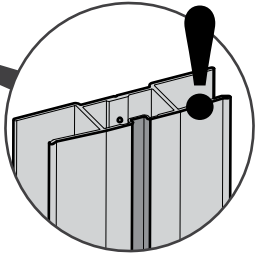
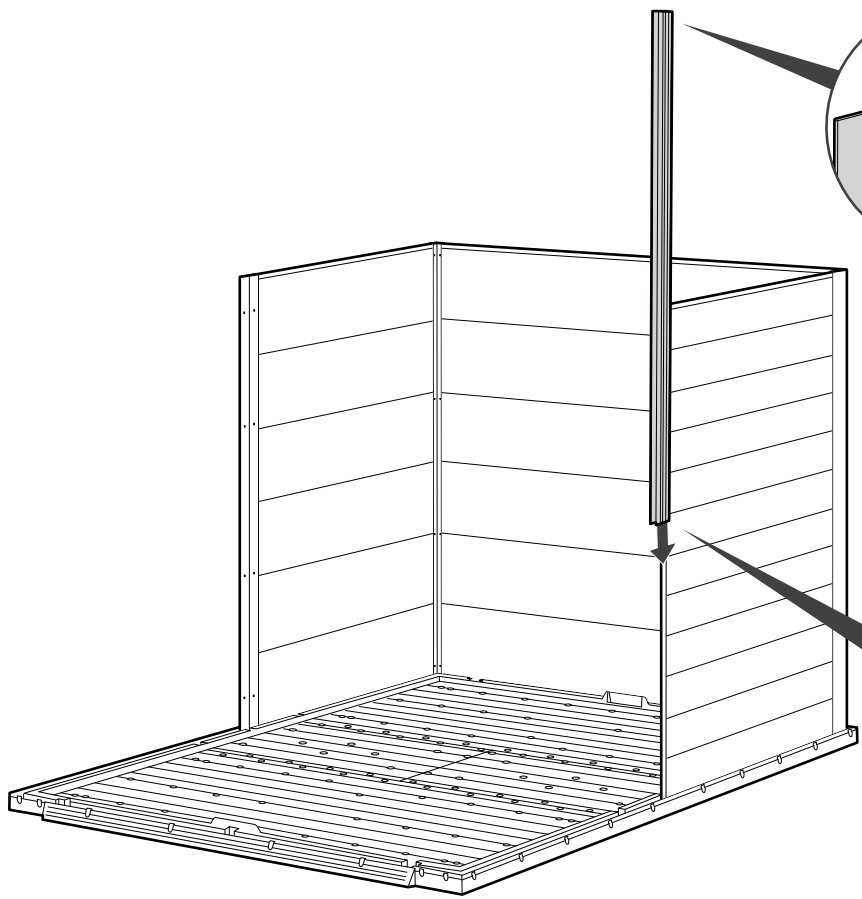
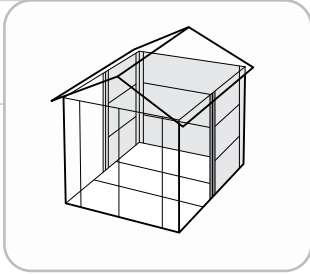

15

 s13b (x8)

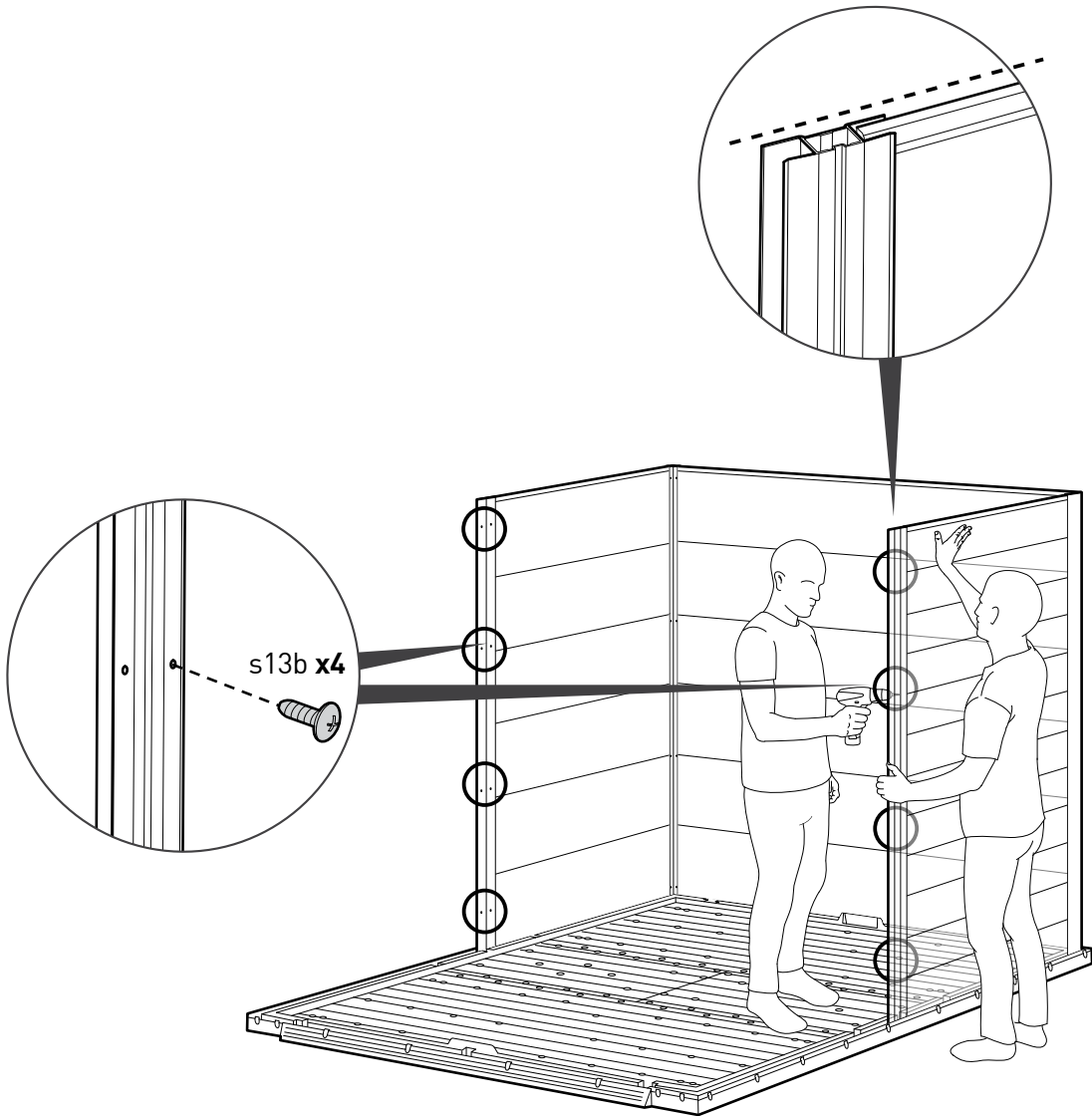
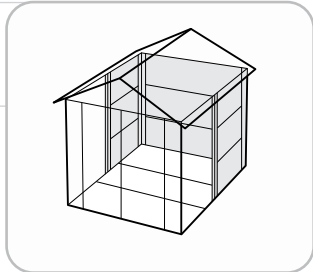

16

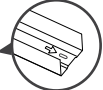

NEHSC (x2)

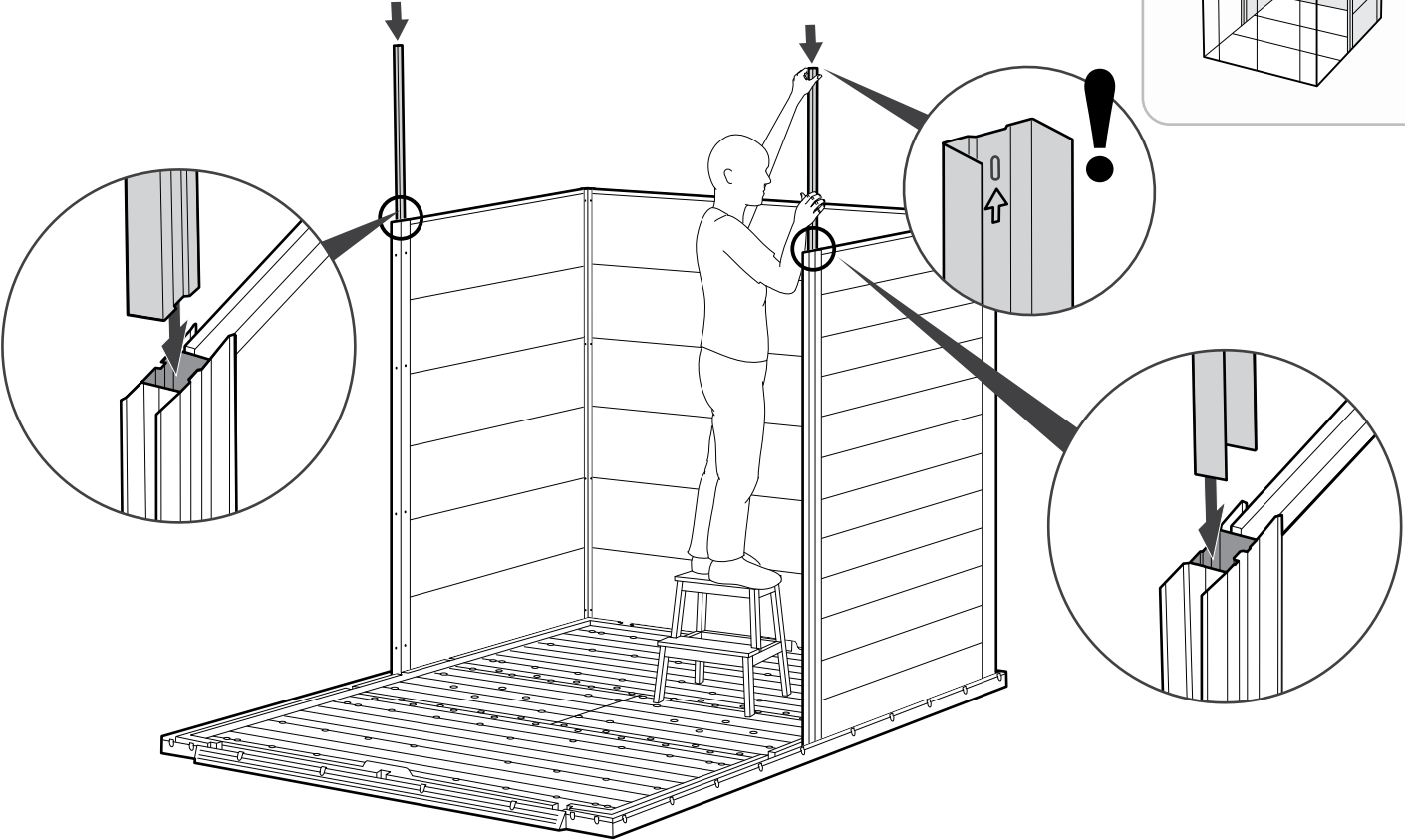
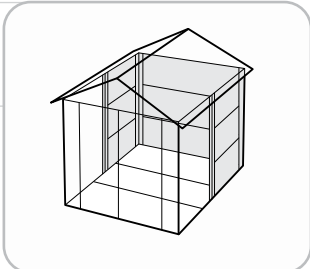

17



NEMS (x2)

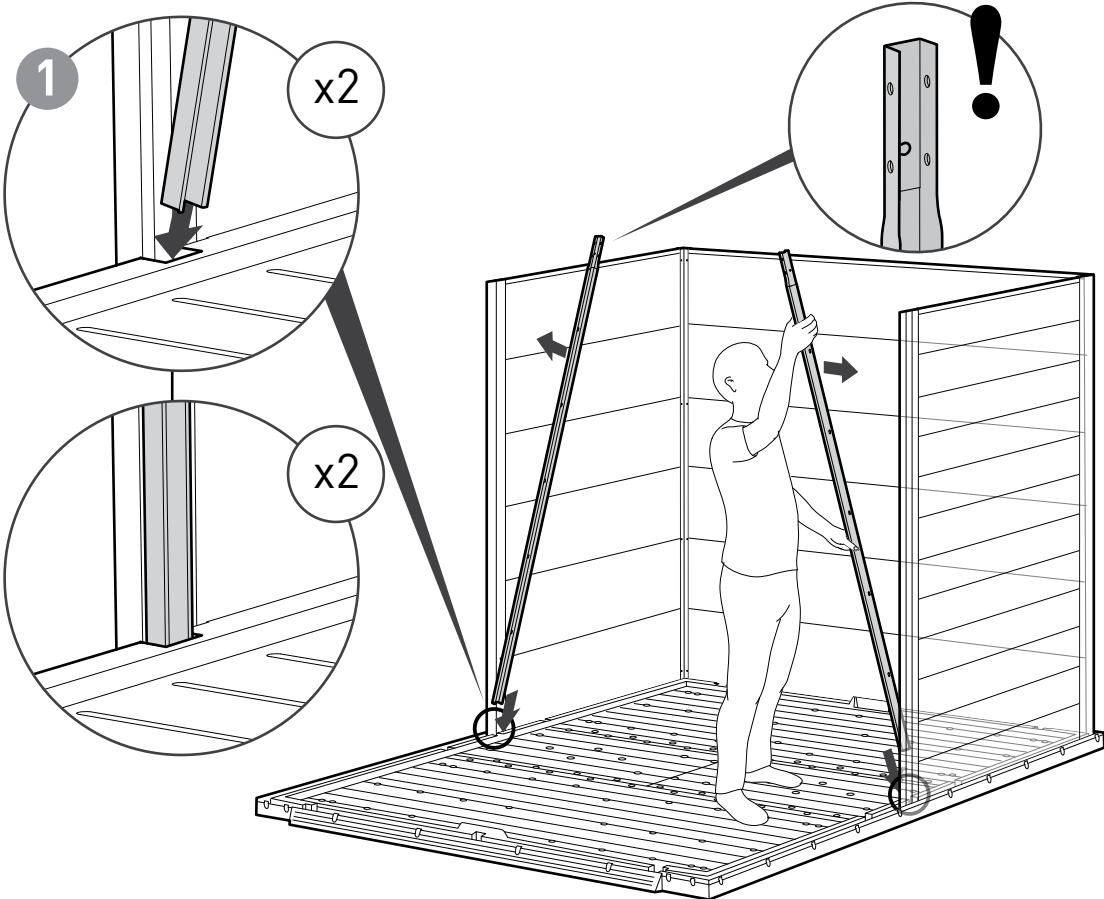
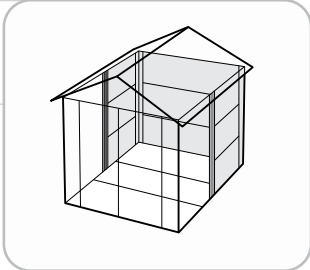

18

sc15 (x6)

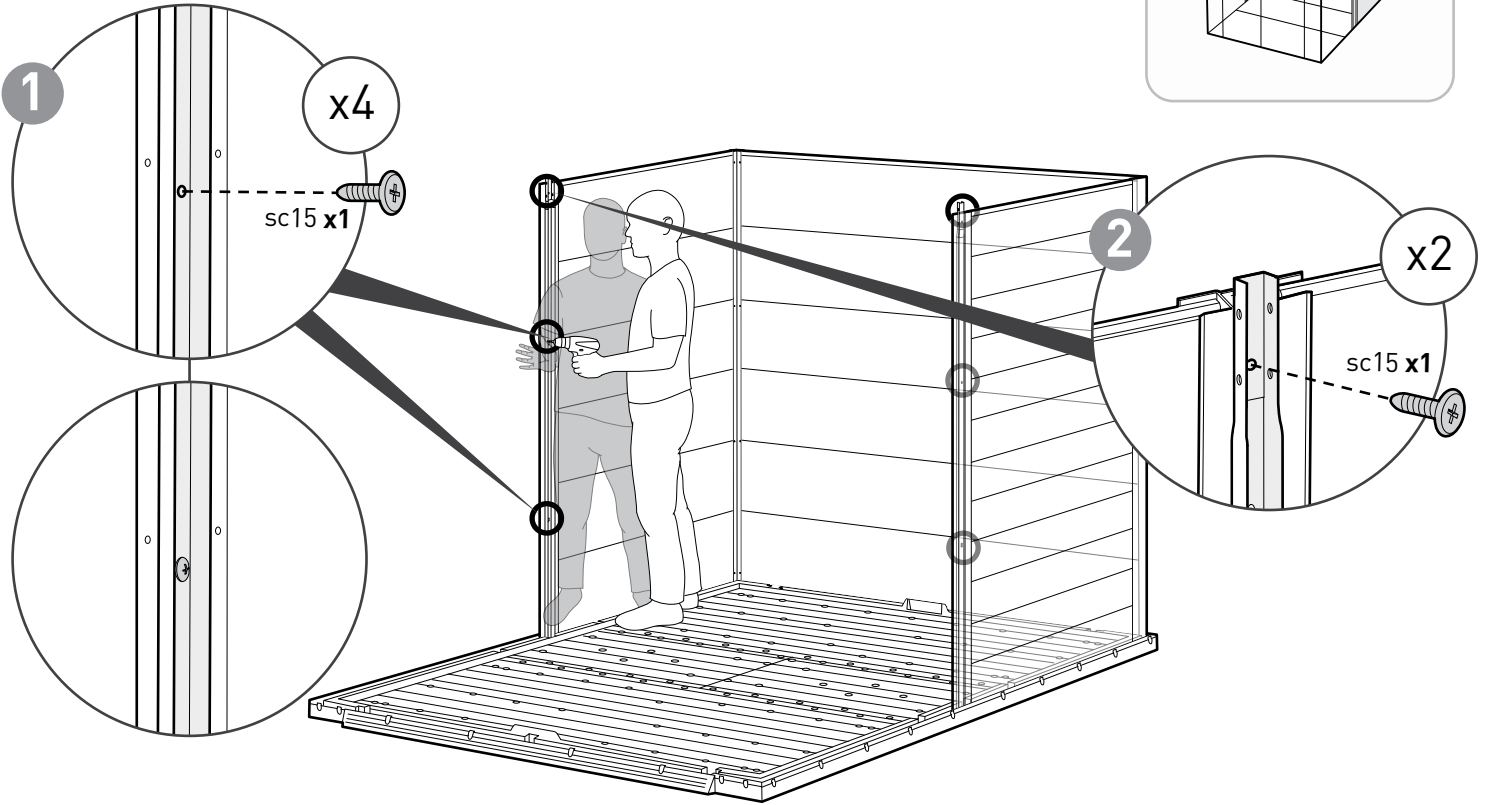
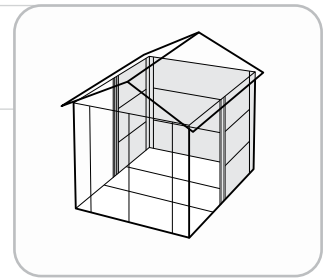

19

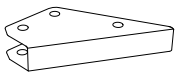

FNME (x2)

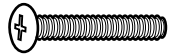

sc8 (x2)



scn8 (x2)

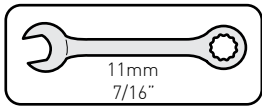
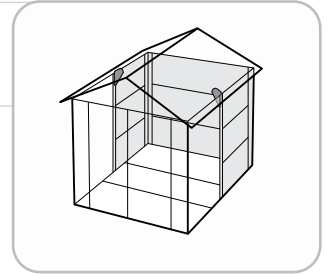

11mm
7/16"

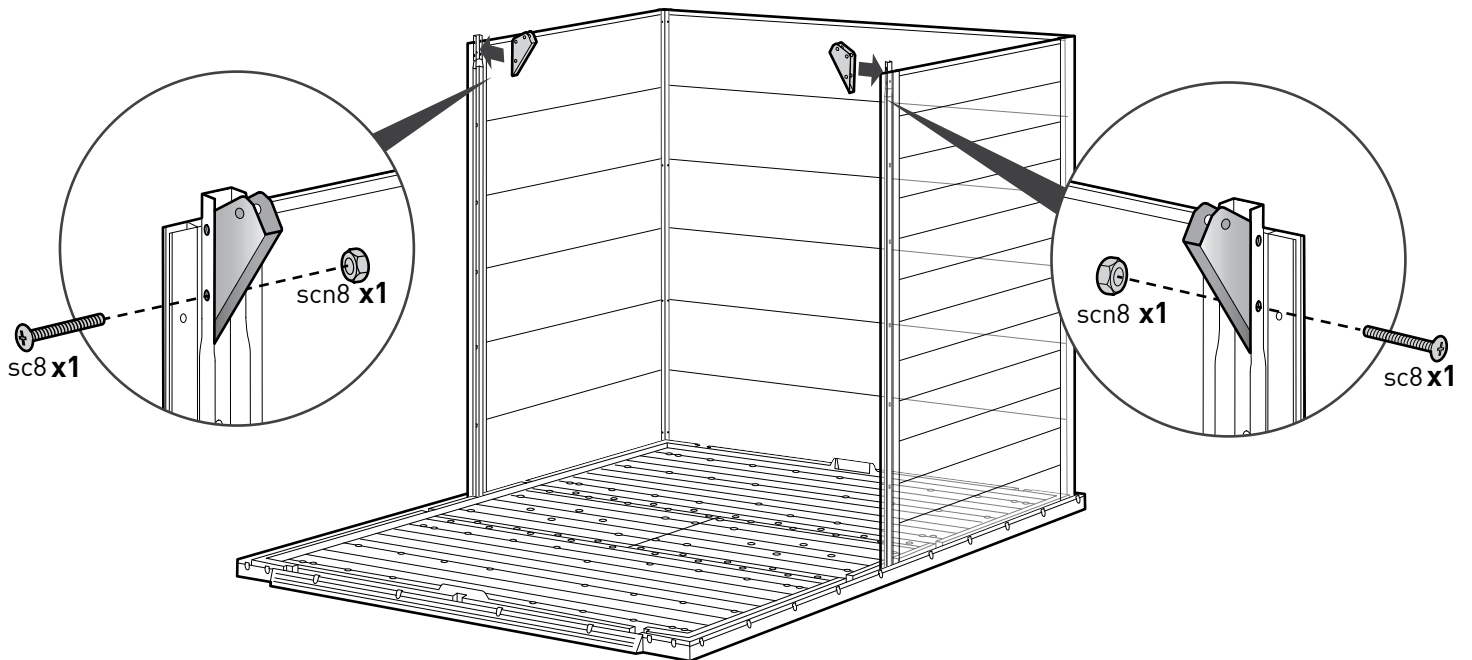

- 20
- moSF (x2)
- FNMH (x1)
- FNMA (x1)
- sc8 (x6)
- scn8 (x6)

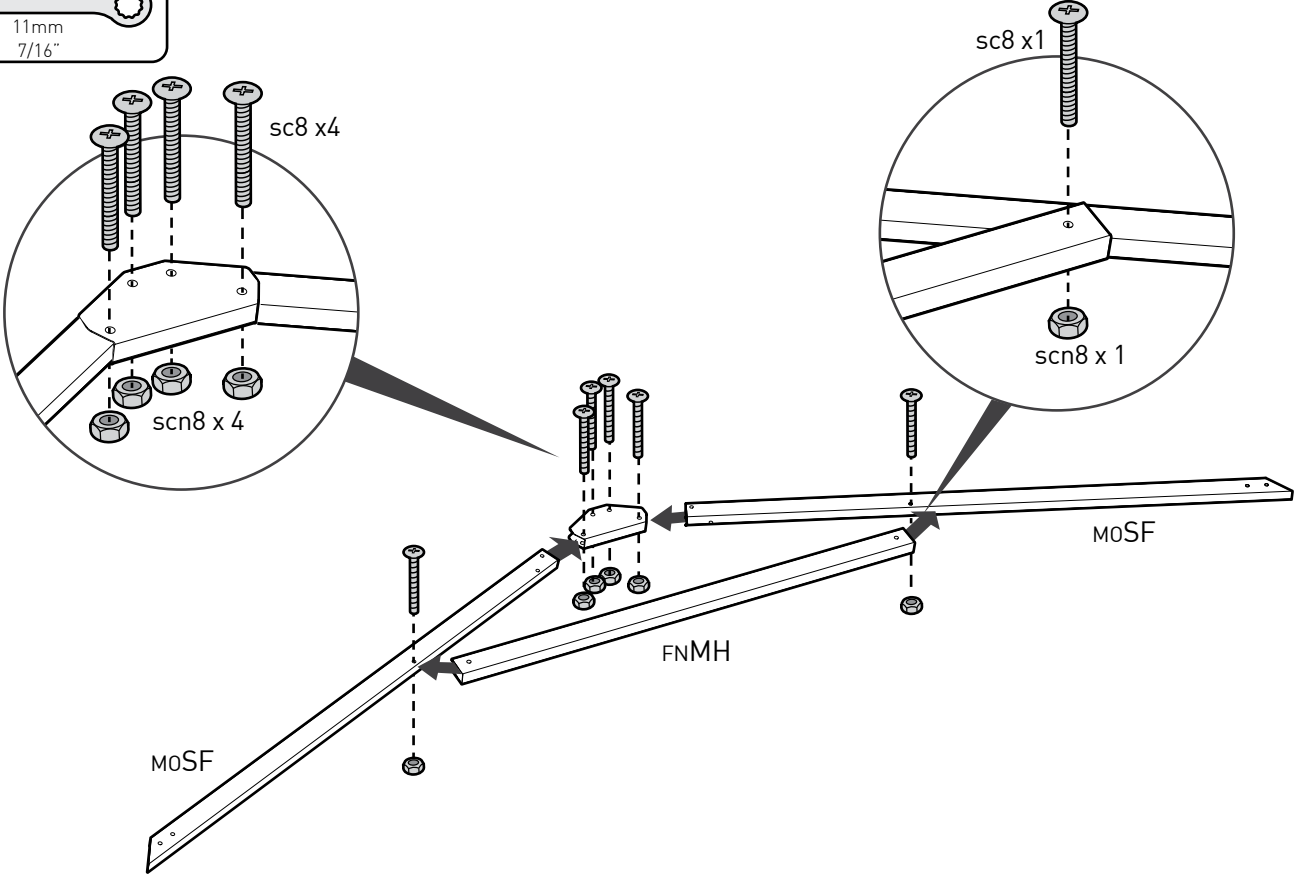
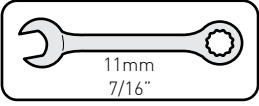

- 21
- sc8 (x4)
- scn8 (x4)
- Icon of two people
- Icon of a house structure

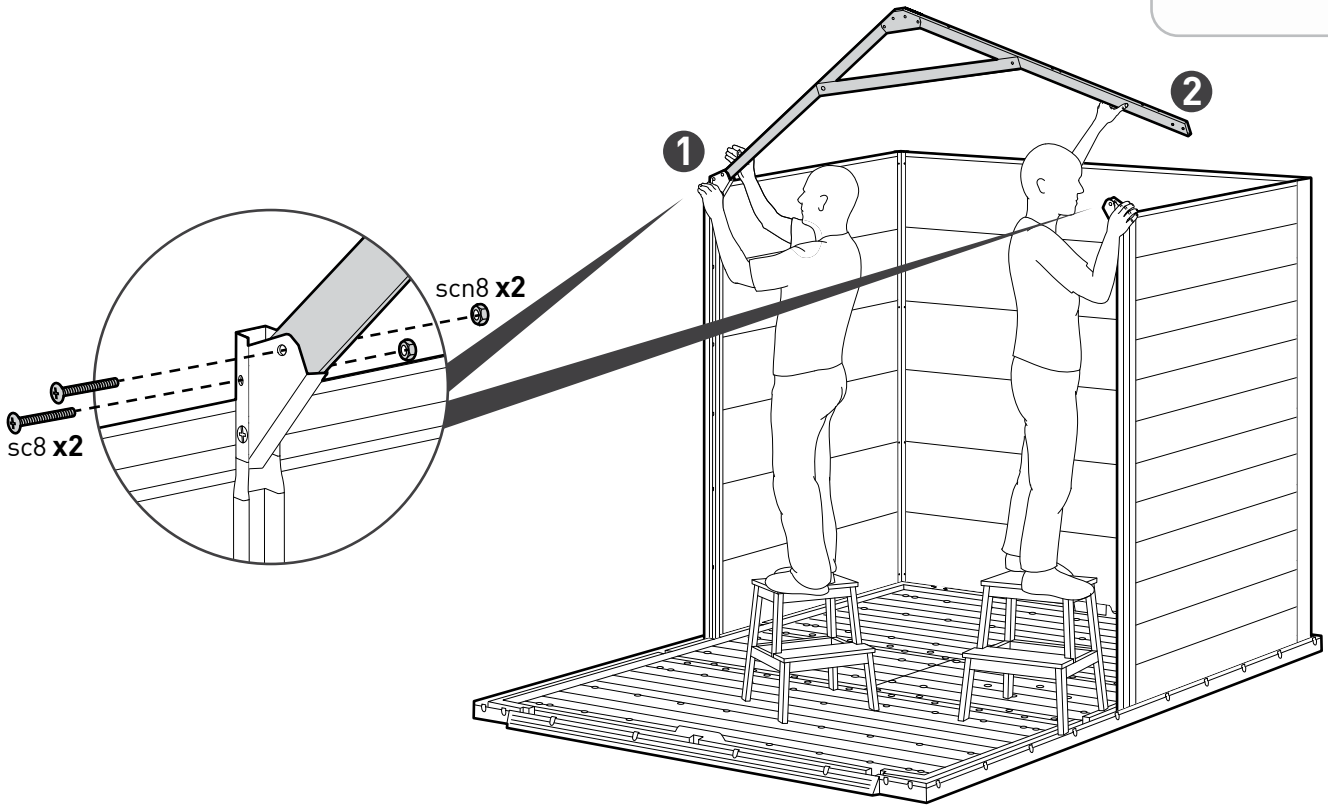
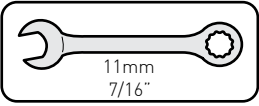

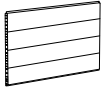

NEPB9 (x2)



NEDF (x2)

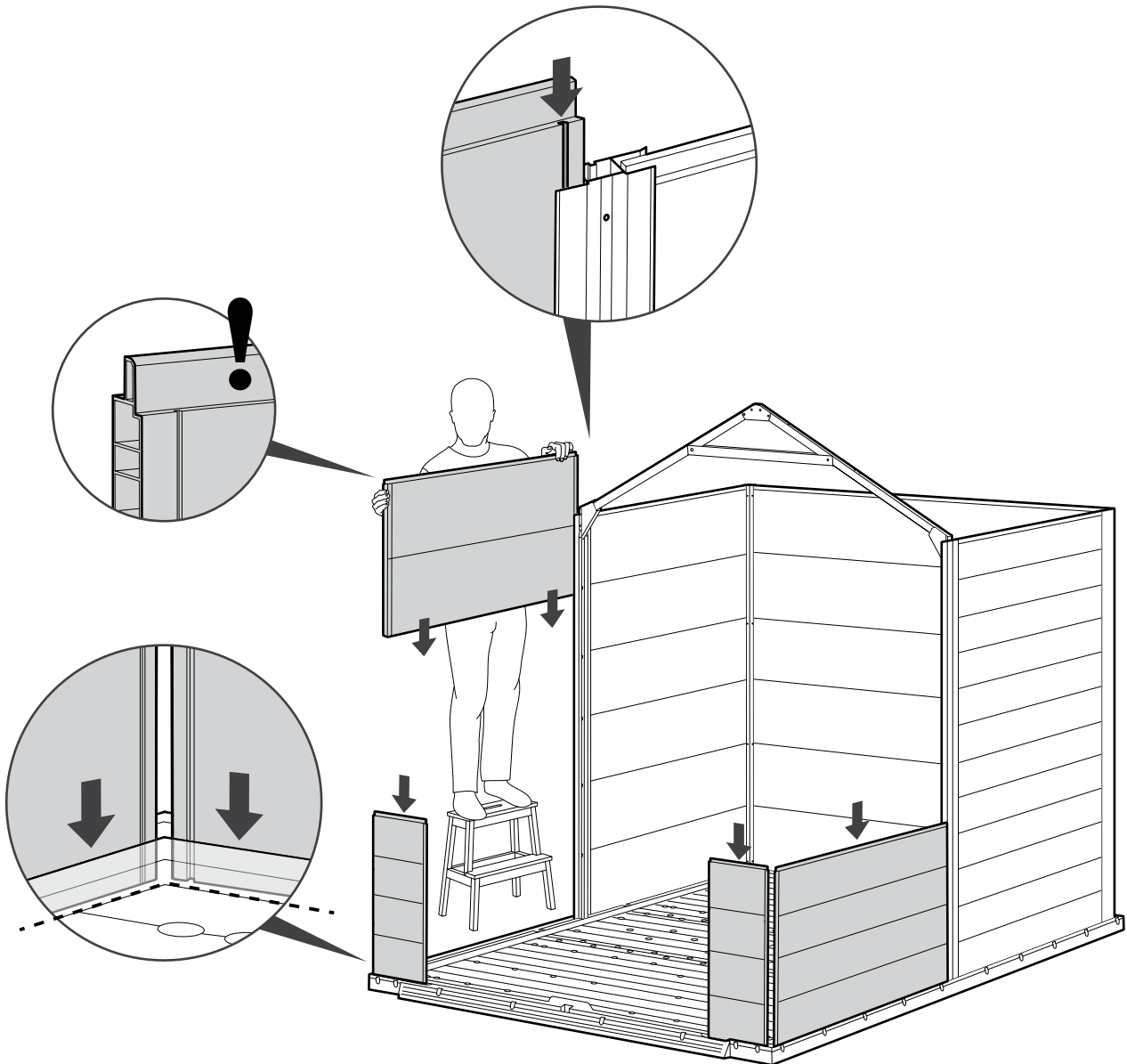
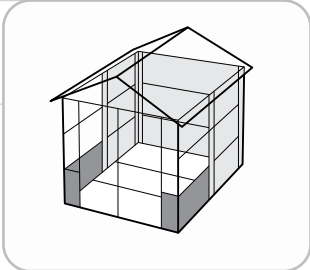

23

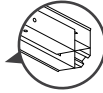
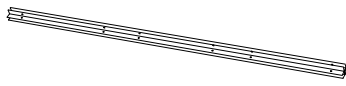

NECA (x2)

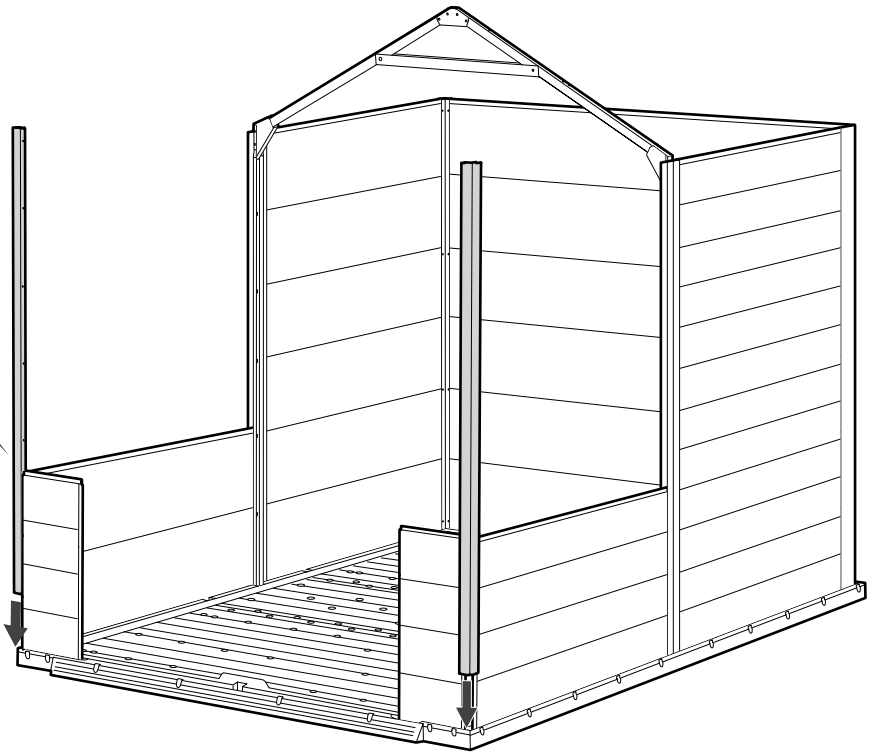
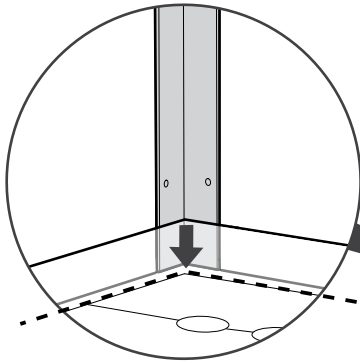
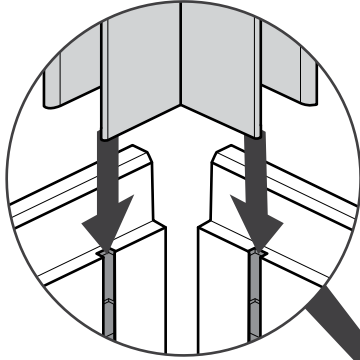
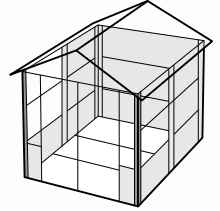

24

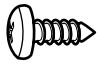

S13b (x4)

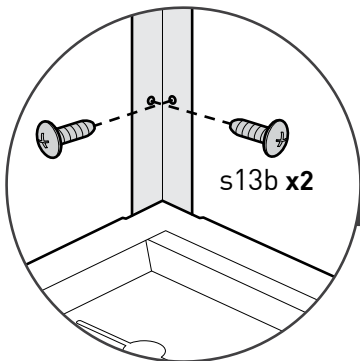
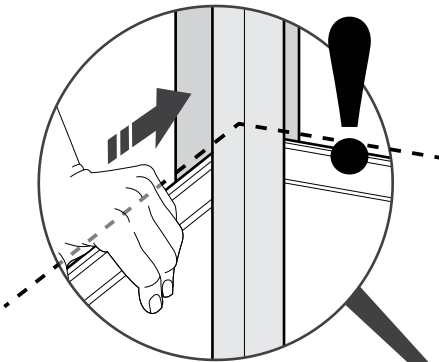
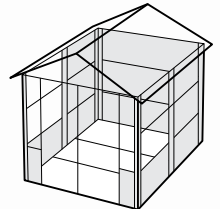

s13b x2

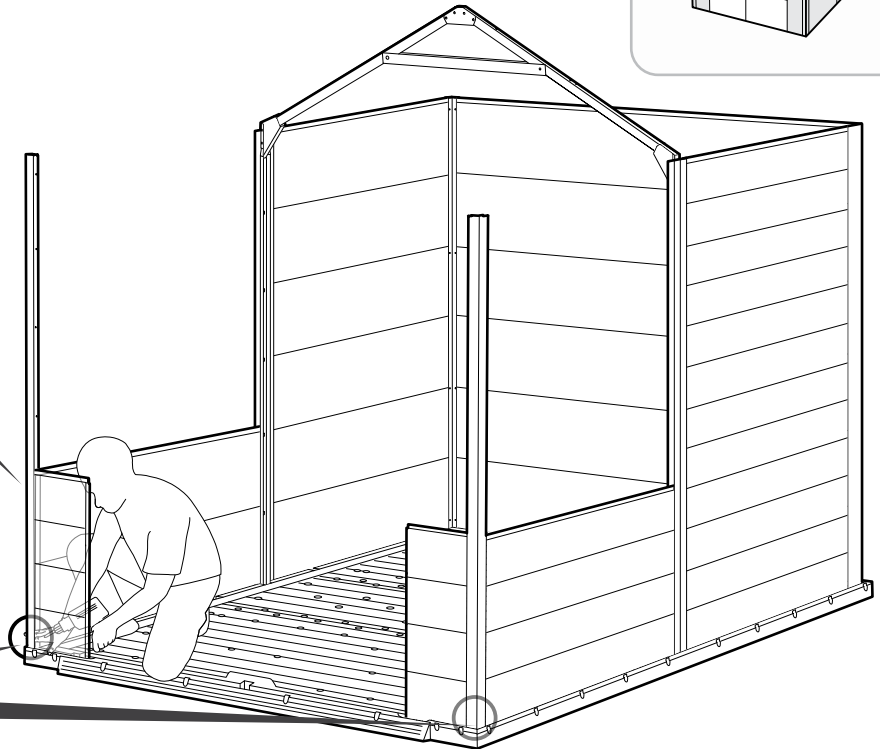

25

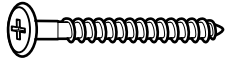

S45b (x2)

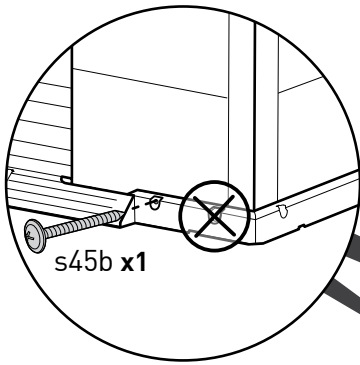
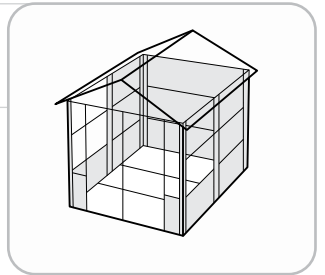

s45b x1

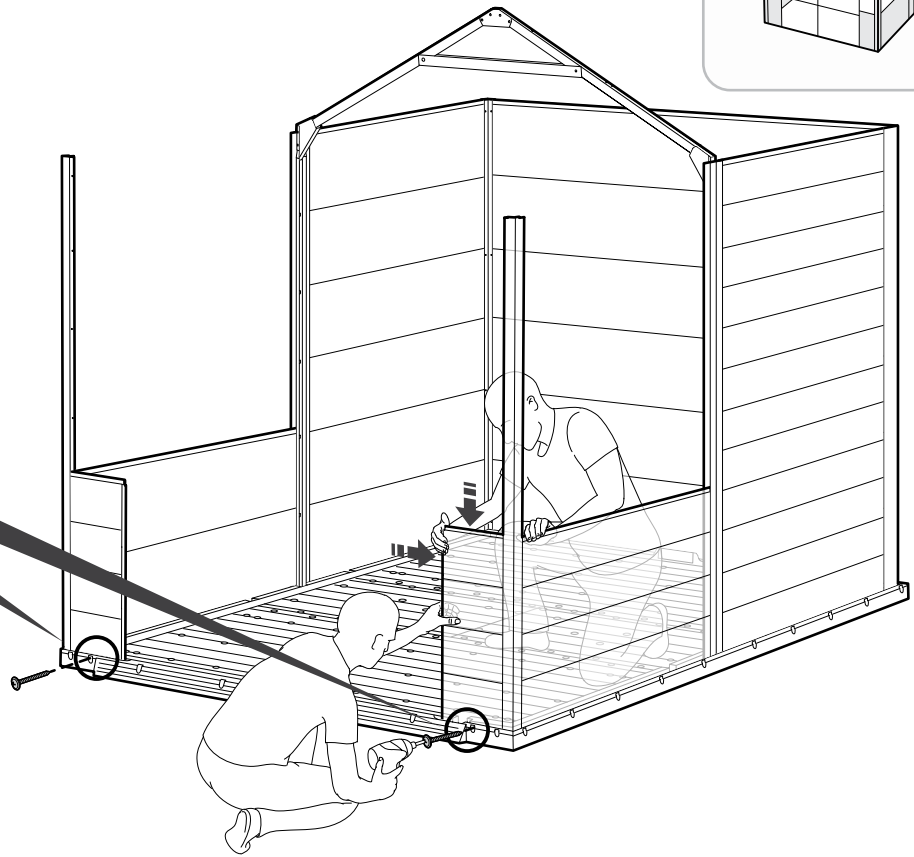

26

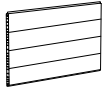

NEPB9 (x2)



NEDF (x2)

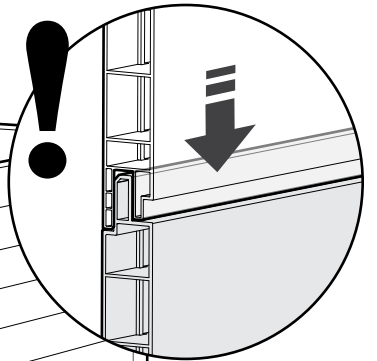
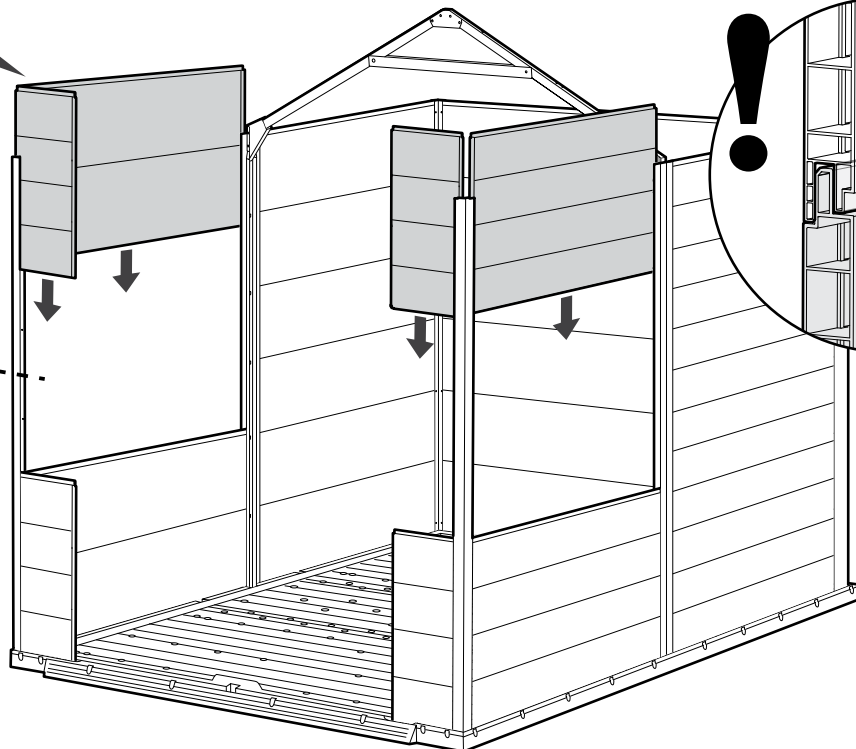
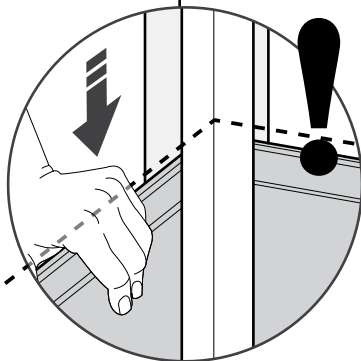
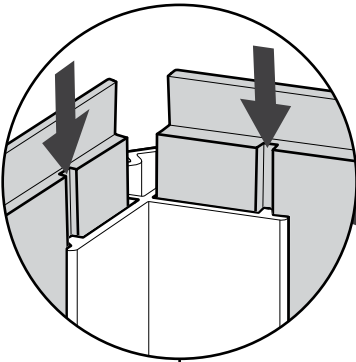
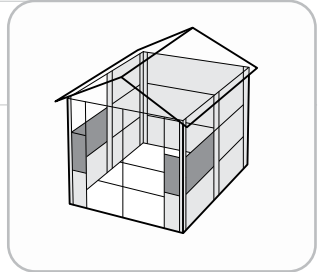

27

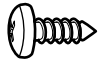
 s13b (x4)

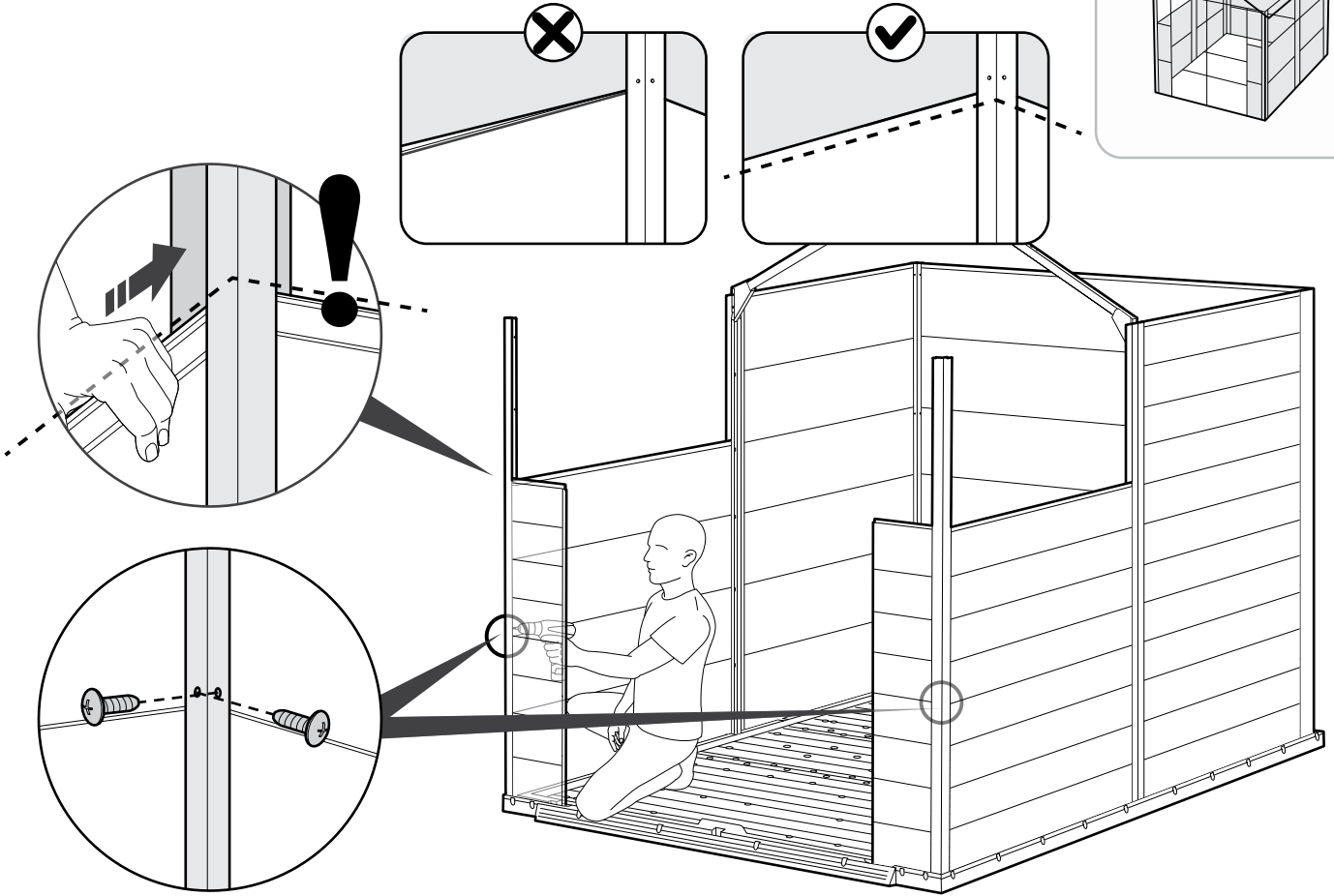
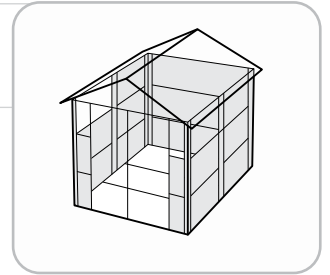

28

 NEPB9 (x2)

 NEDF (x2)

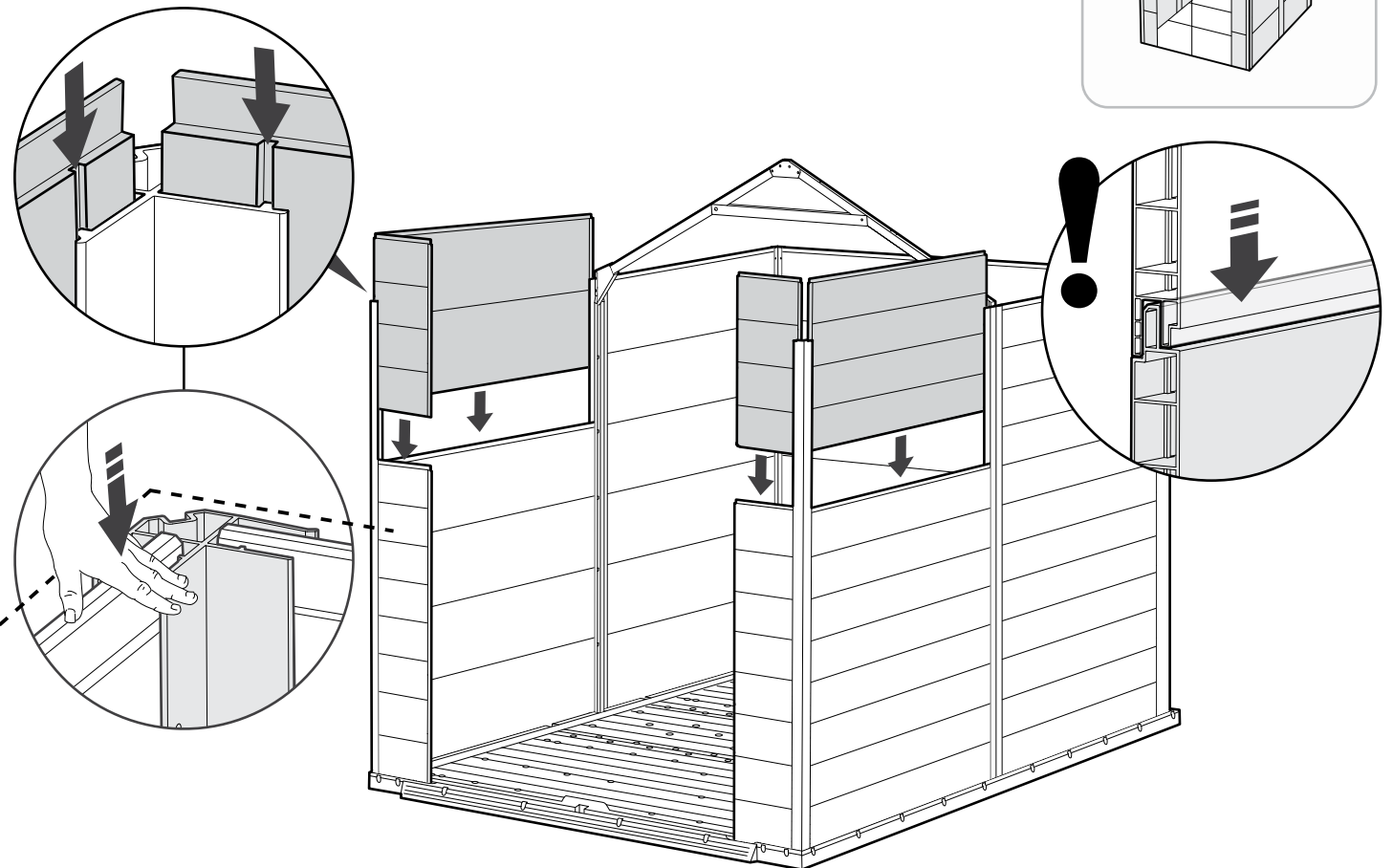
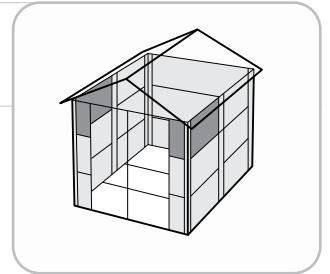

29

s13b (x8)

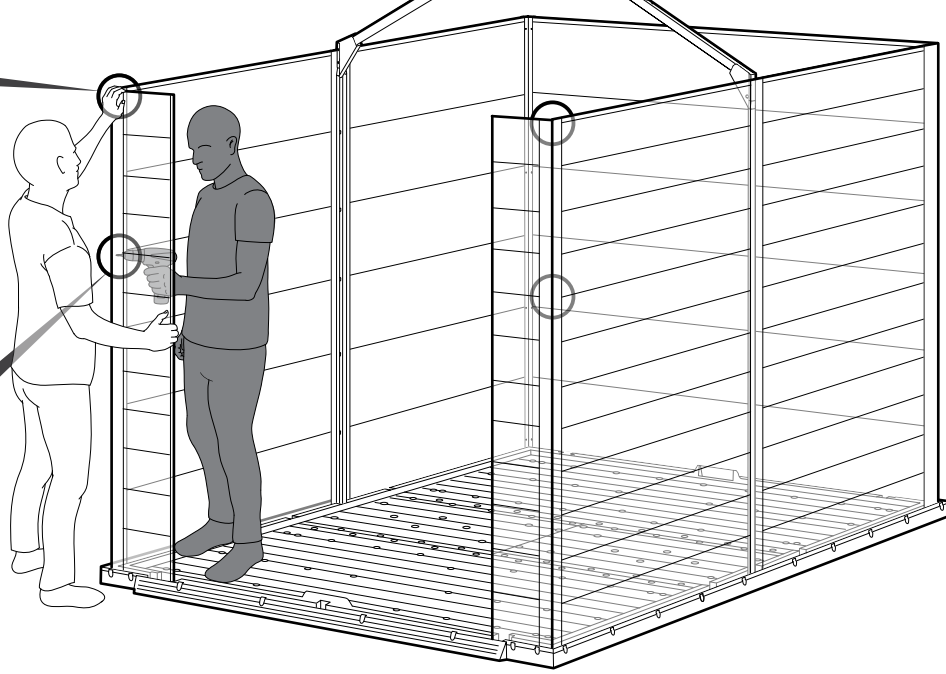
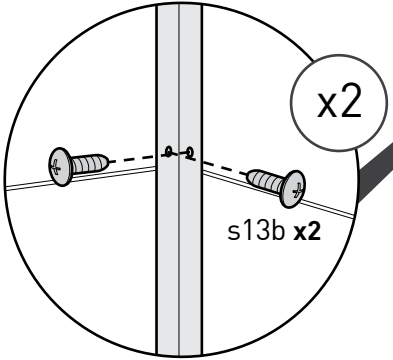
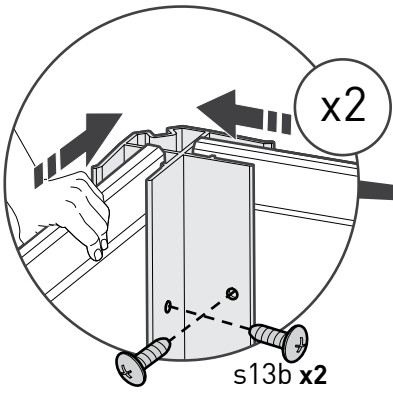
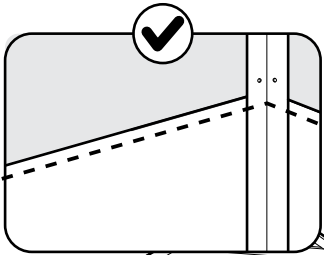
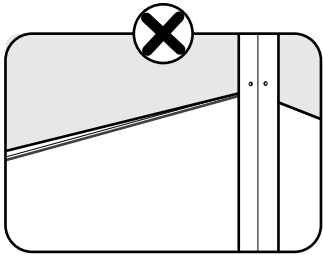
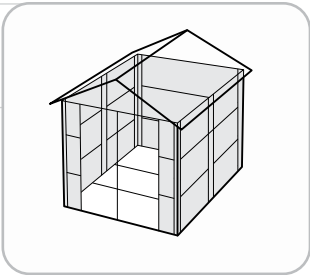

30

s13b (x8)

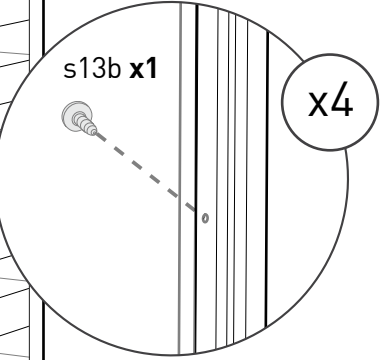
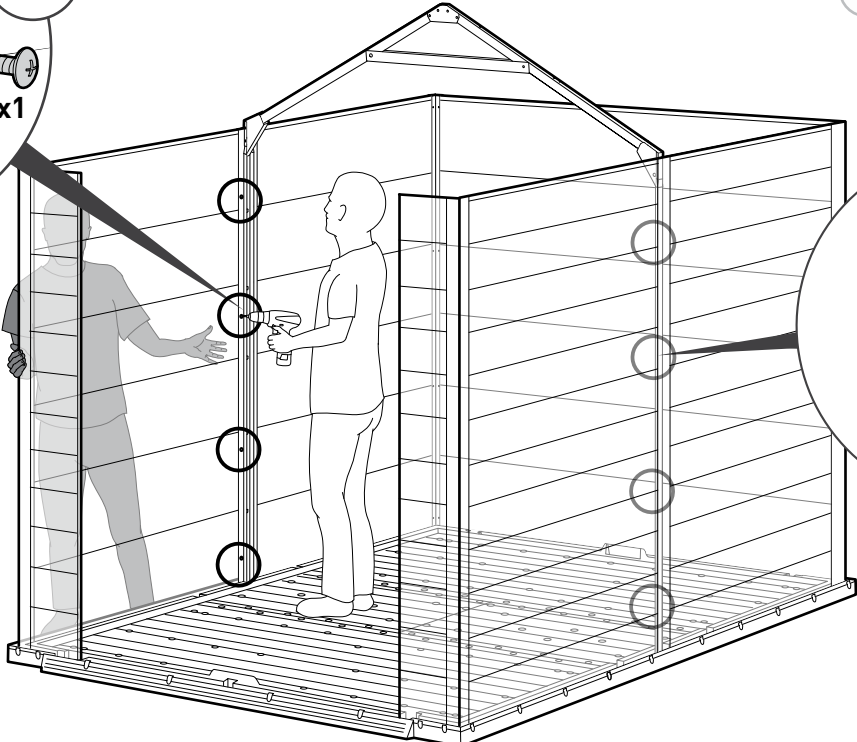
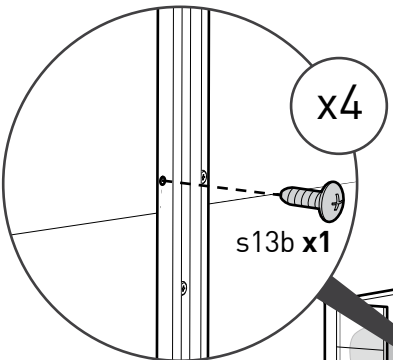
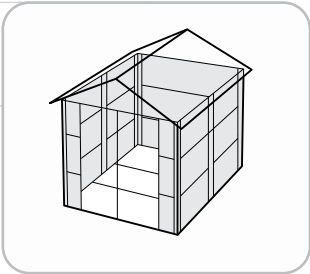

31



NELR (x2)

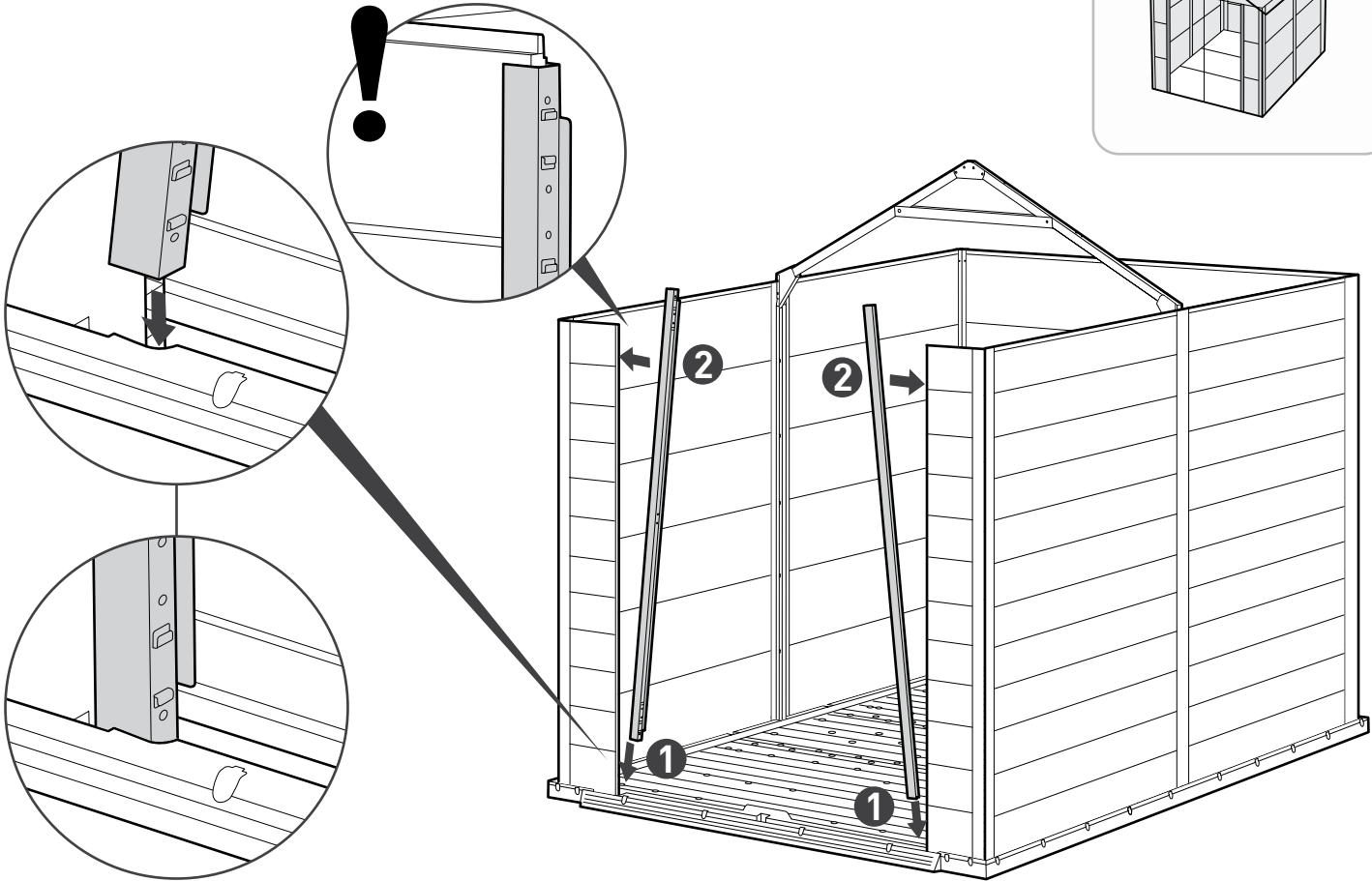
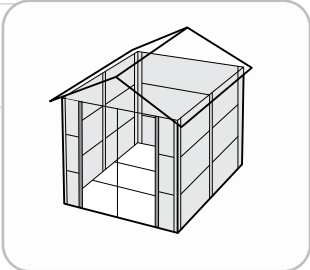

32



NEUK (x1)

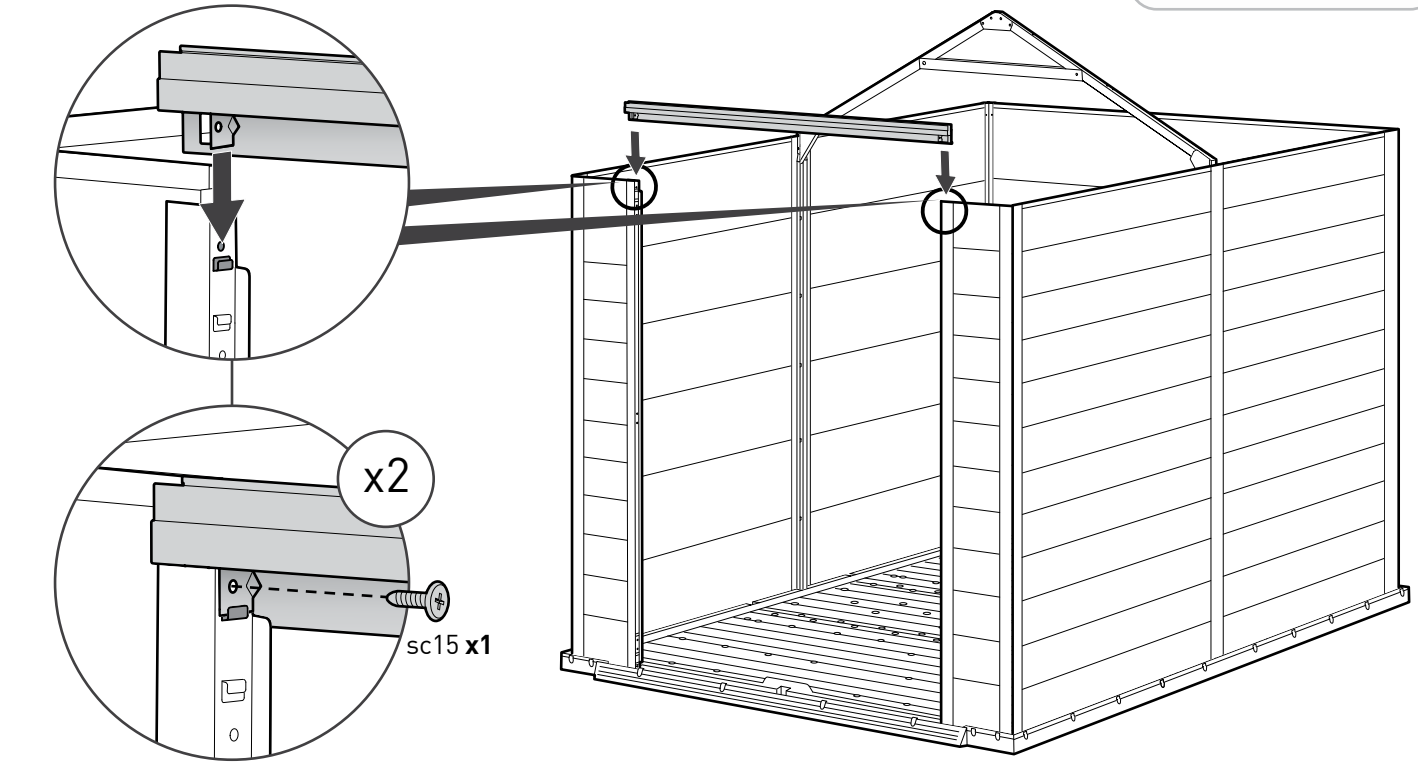
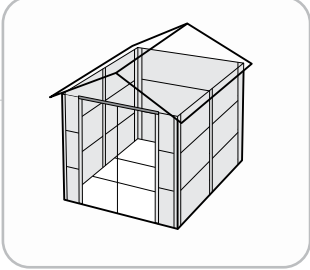

33

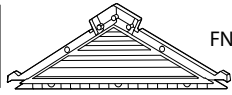

FNAV (x1)

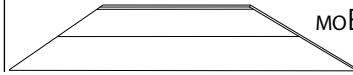

moBTP (x1)

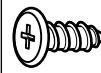

sc15 (x2)

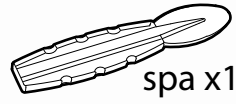
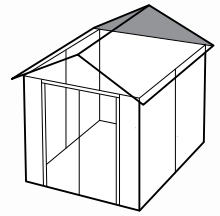

spa x1

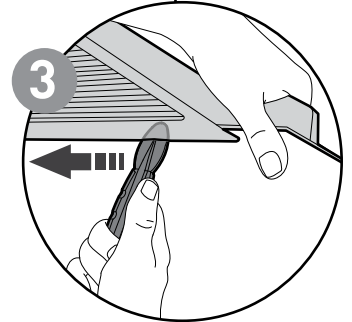
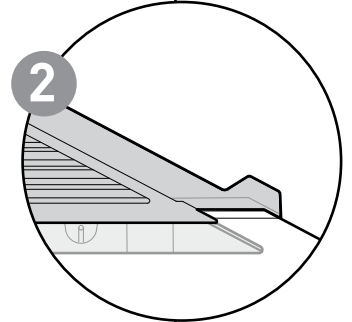
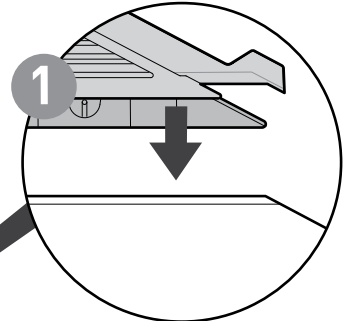
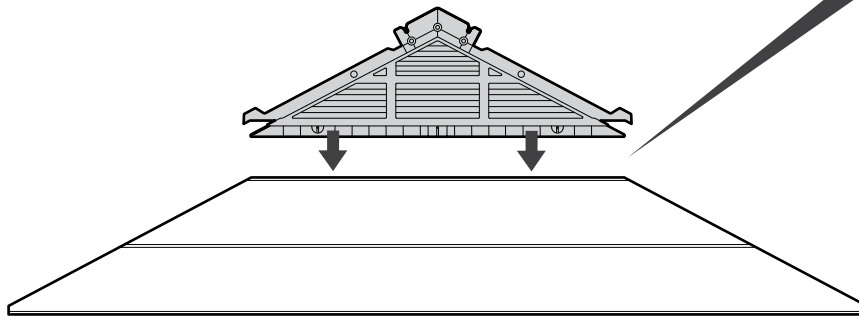
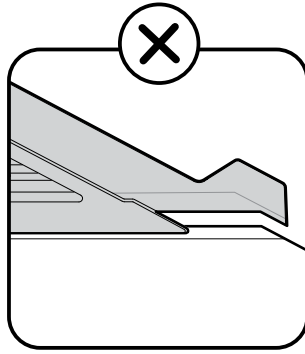
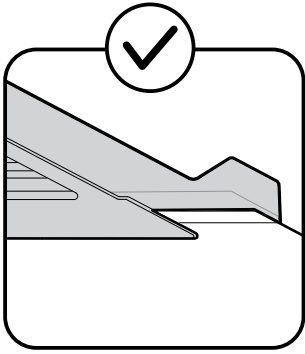

No pre-drilled holes | Pas de trous pré-perçés | Sin agujeros pretaladrados |
Ohne vorgebohrte Löcher | **Geen voorgeboorde gaten |** Buchi preforati non presenti | **Sem buracos perfurados previamente**

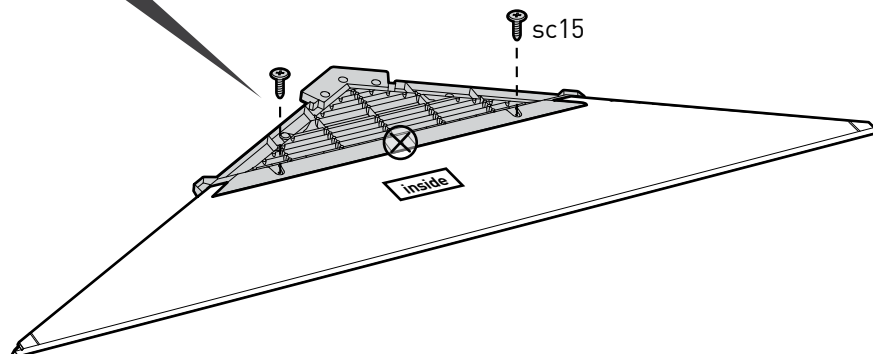
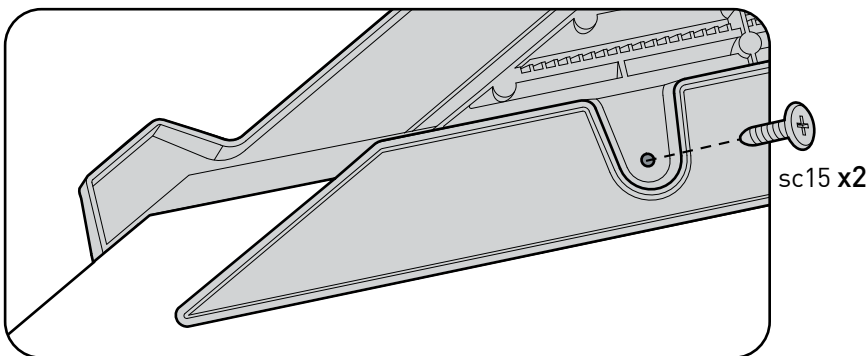

34

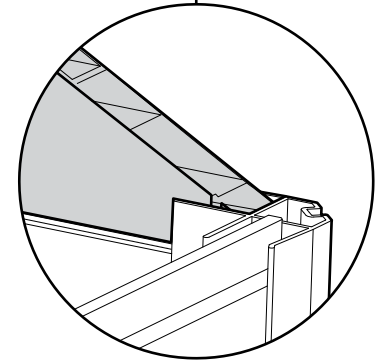
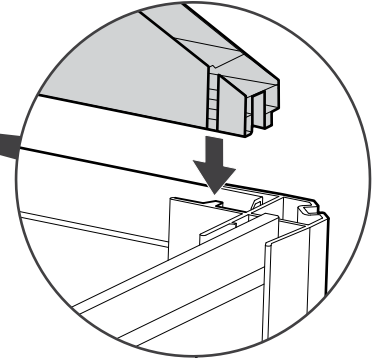
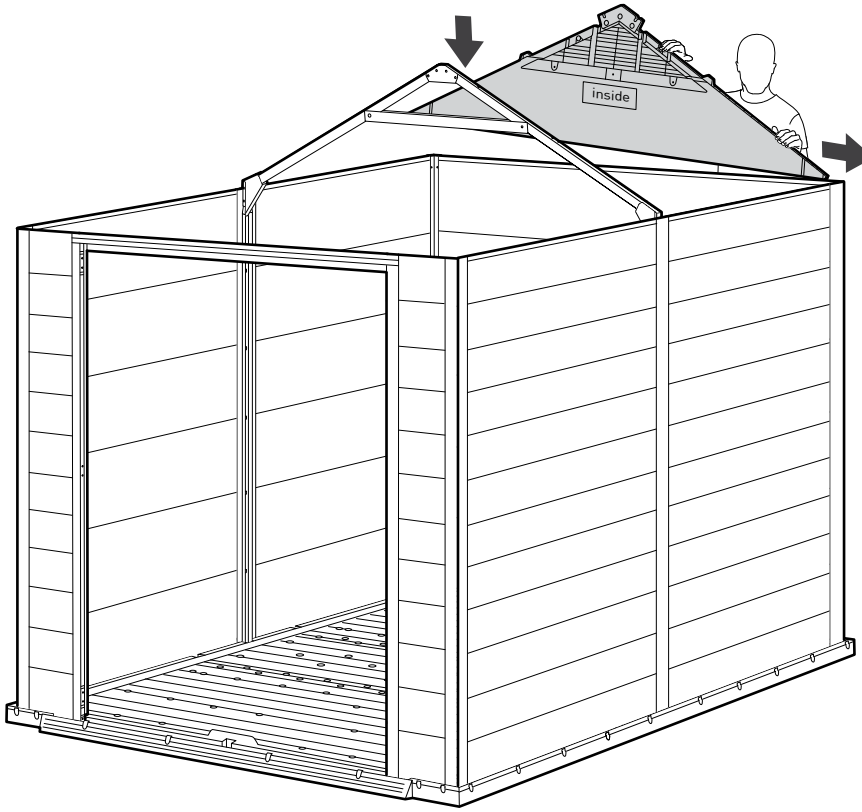
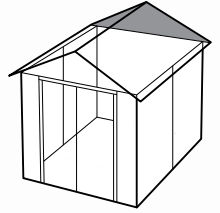
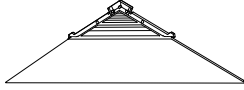

35

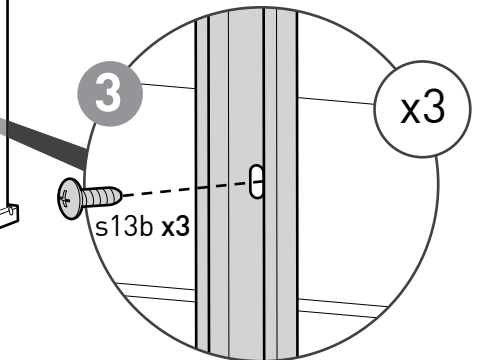
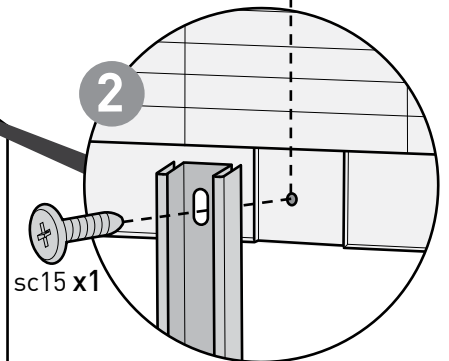
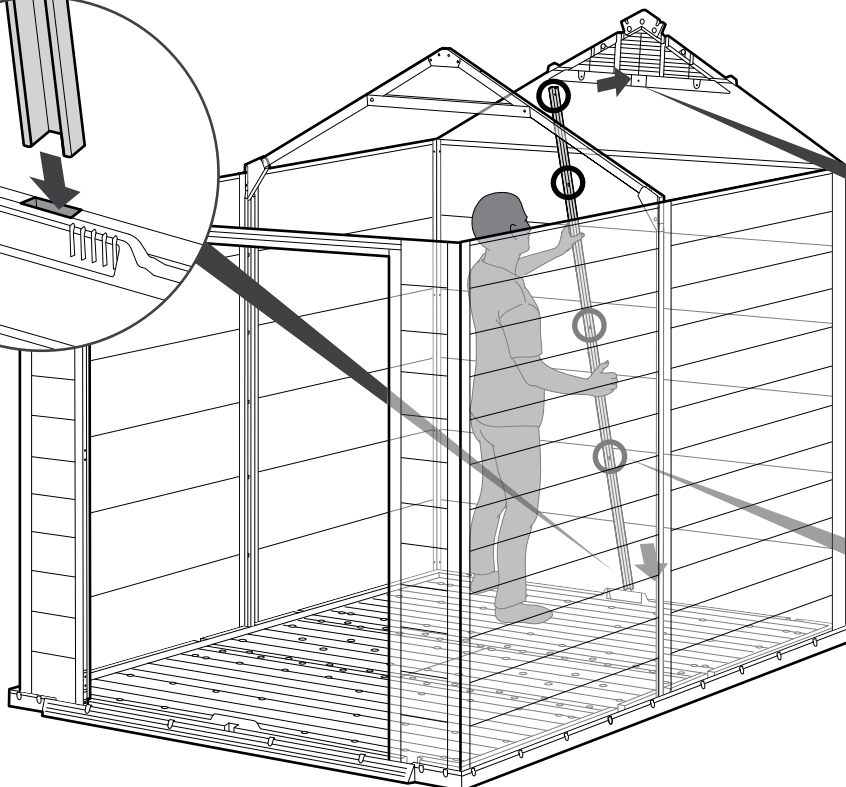
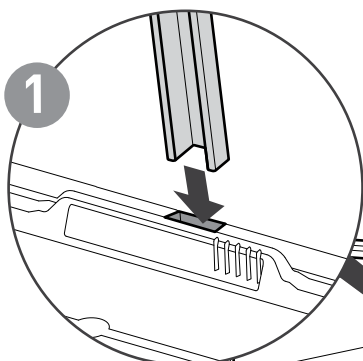
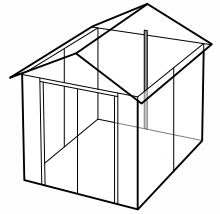
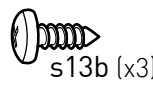

36

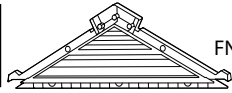

FNAV (x1)

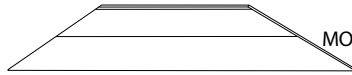

MOBTP (x1)

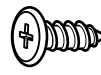

sc15 (x3)

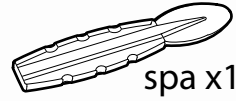
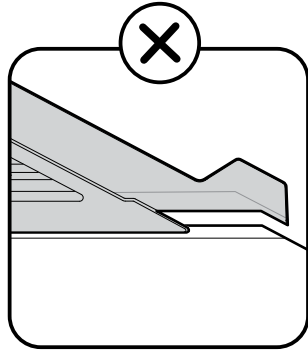
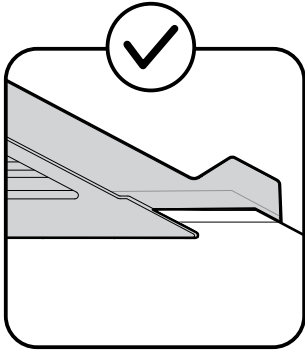
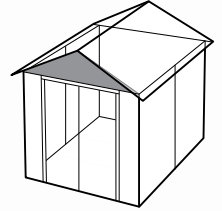

spa x1

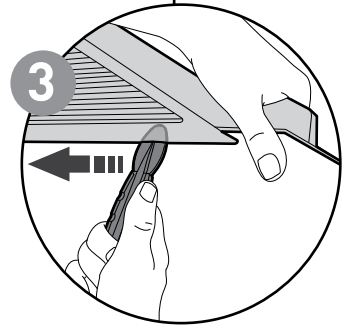
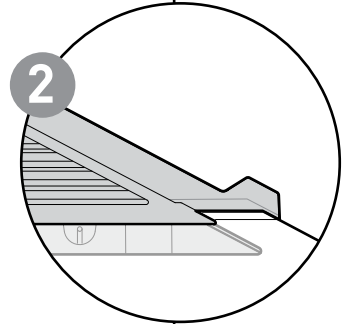
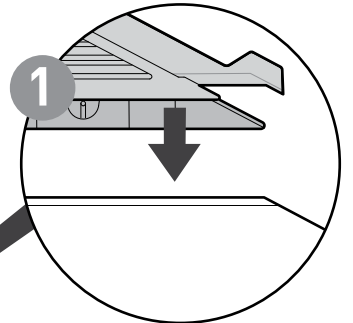
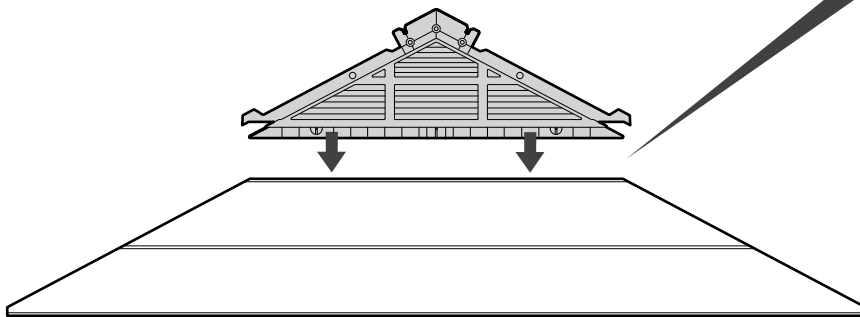

No pre-drilled holes | Pas de trous pré-perçés | Sin agujeros pretaladrados | Ohne vorgebohrte Löcher | Geen voorgeboorde gaten | Buchi preforati non presenti | Sem buracos perfurados previamente

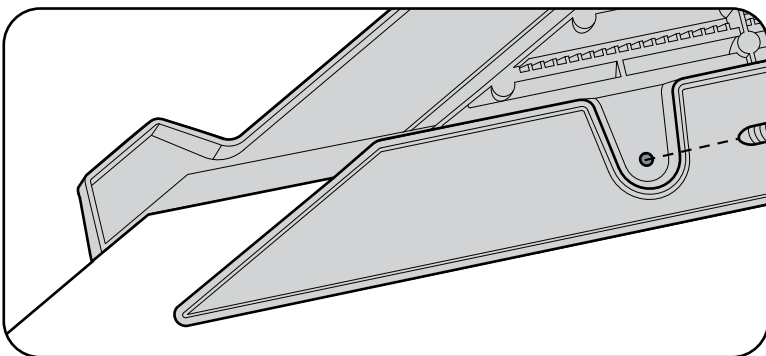

sc15 x3

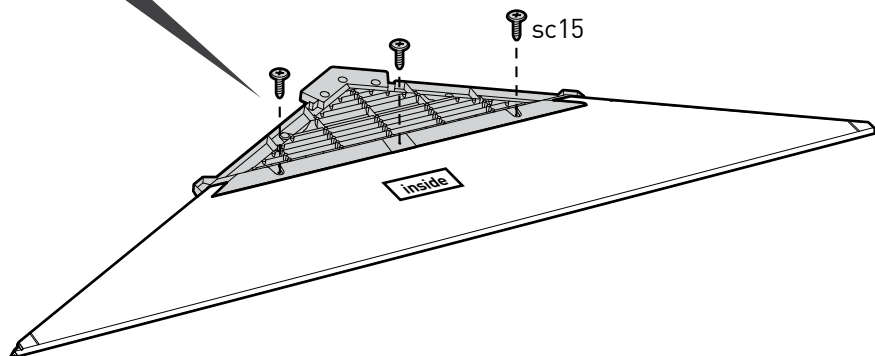

sc15

inside

37

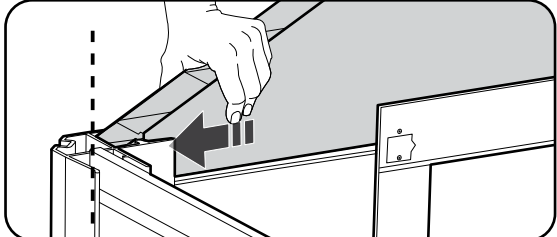
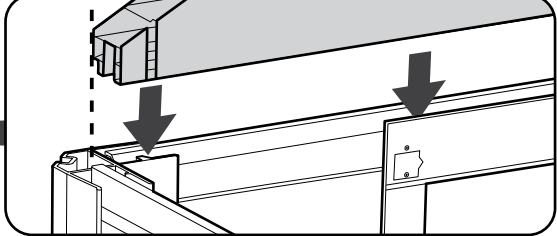
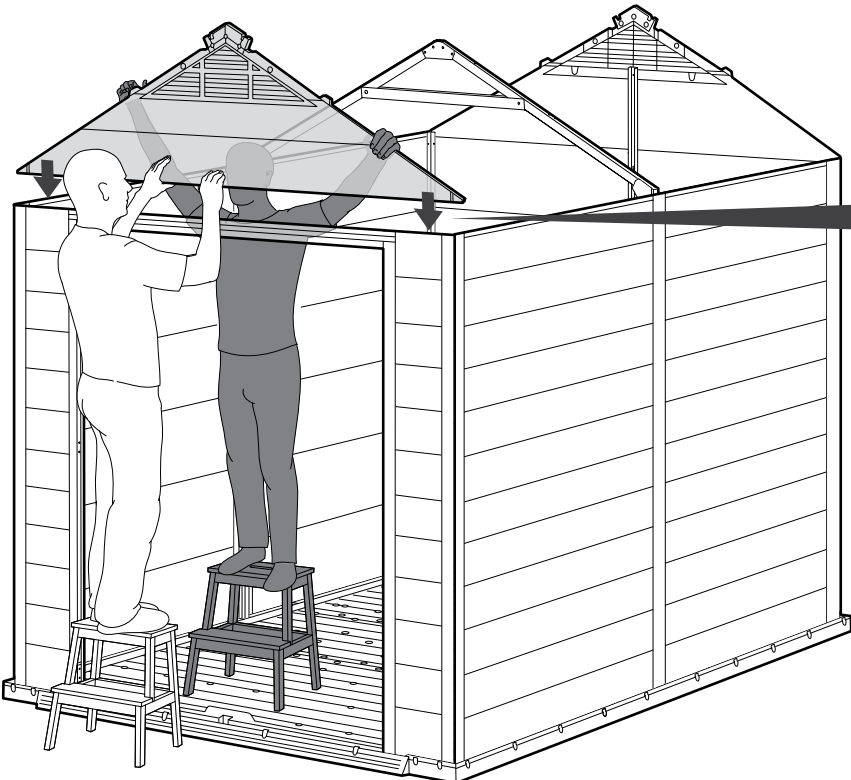
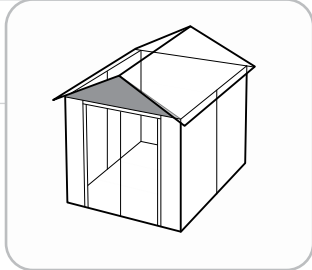
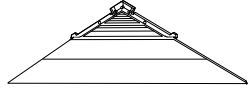

38

 s13b (x2)

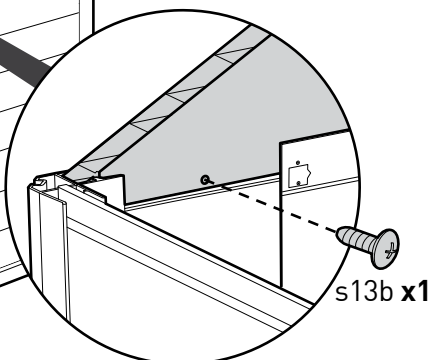
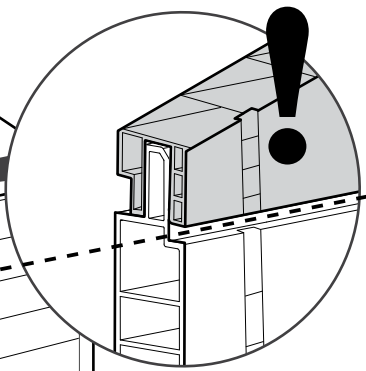
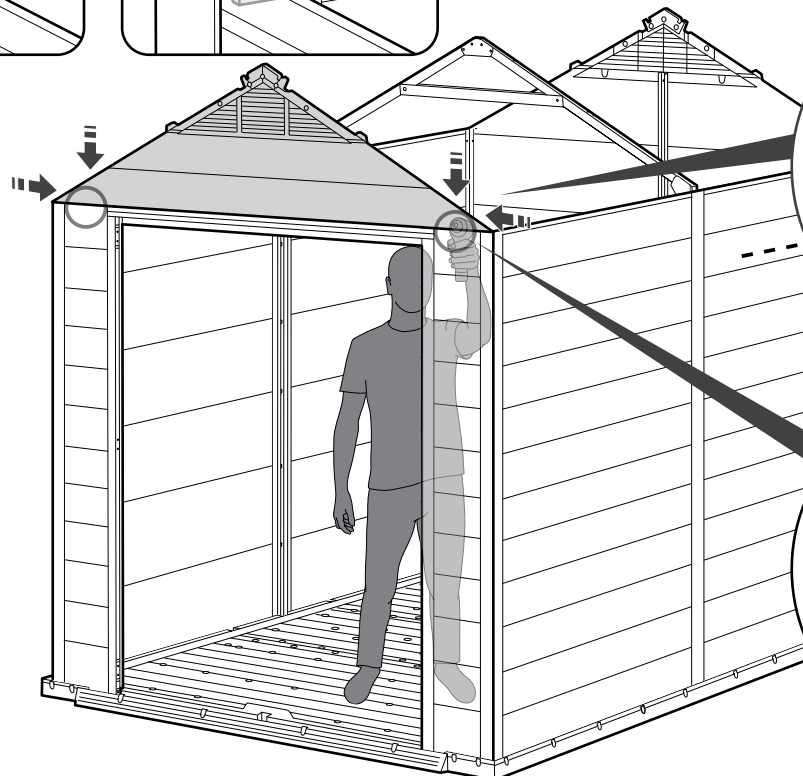
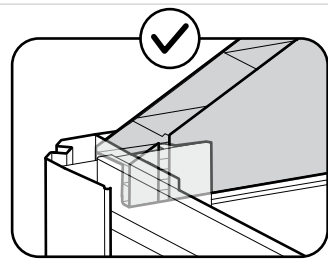
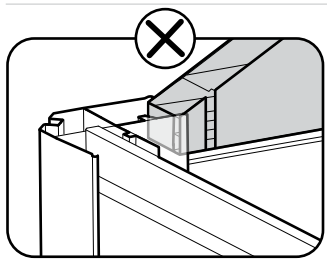
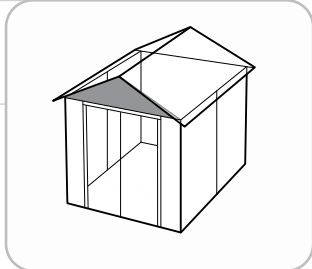

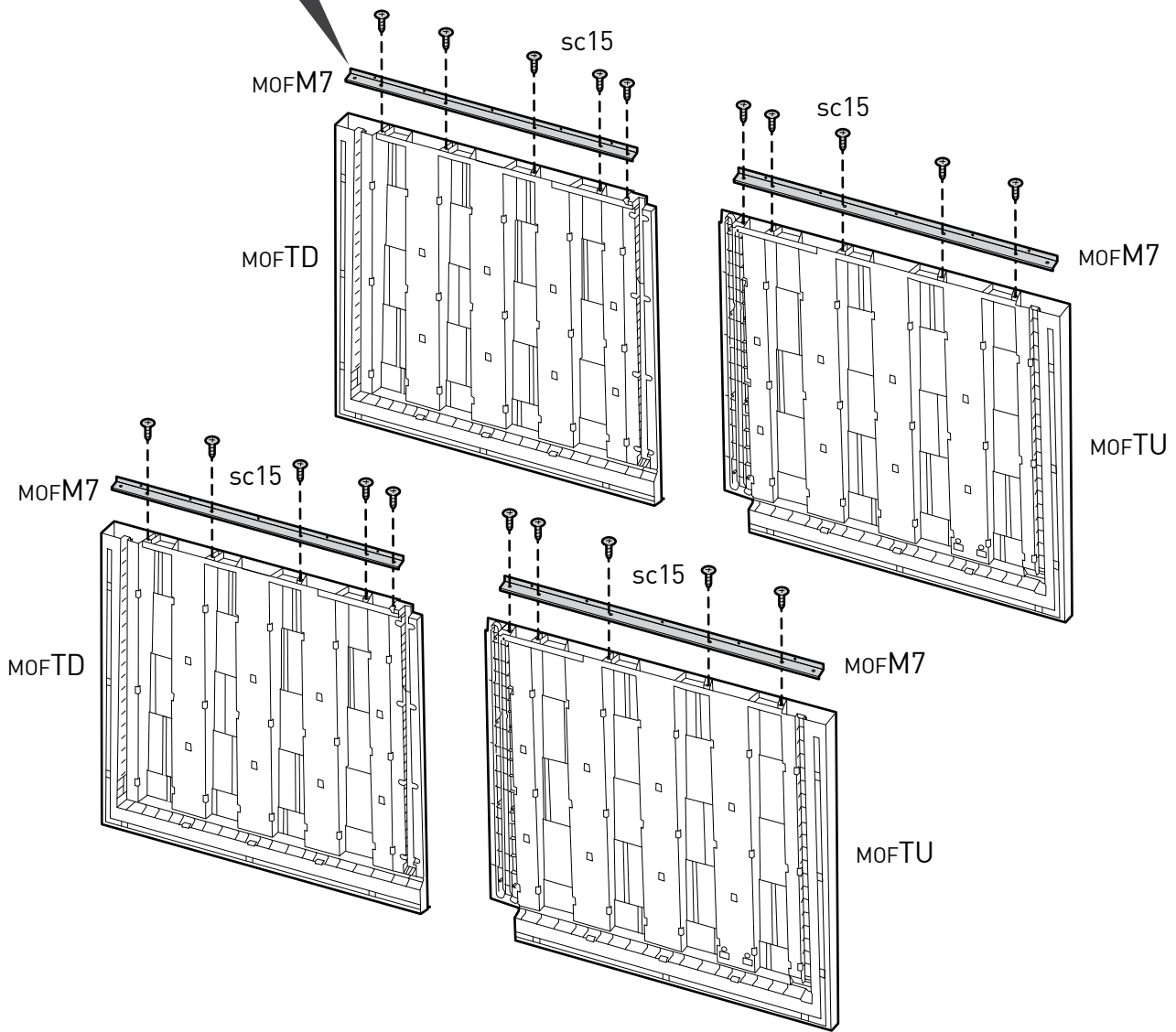
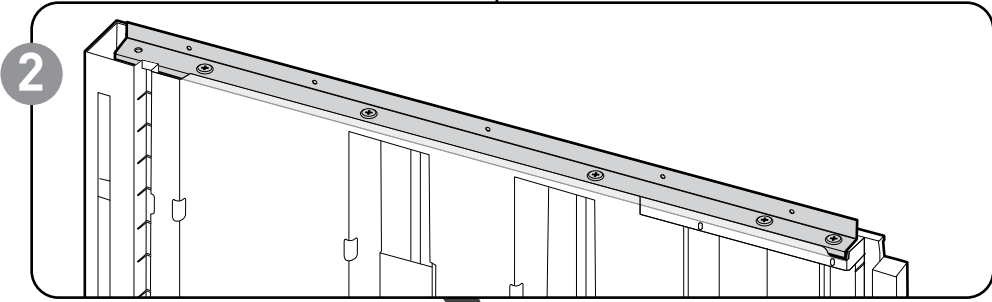
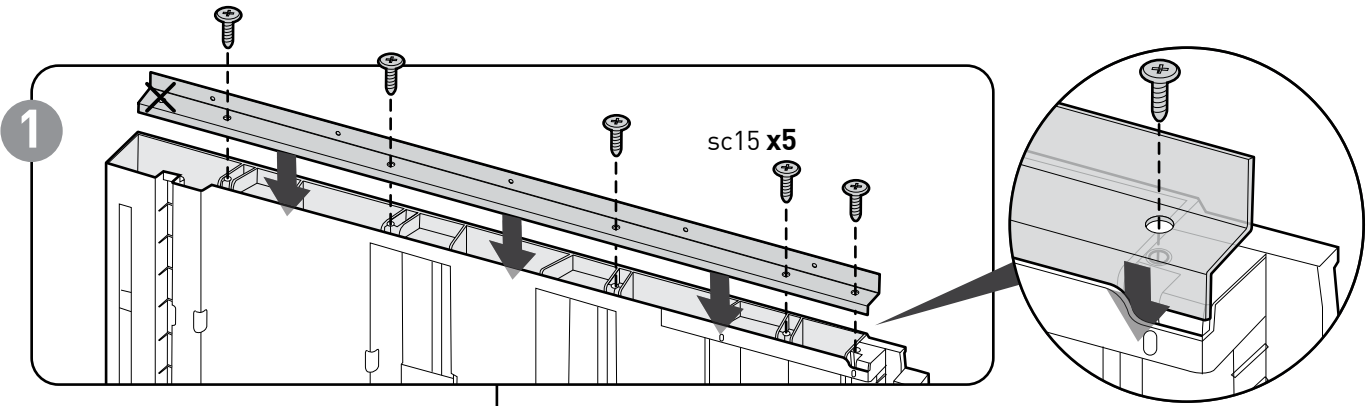
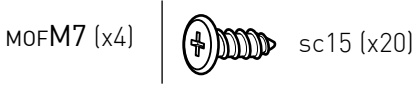
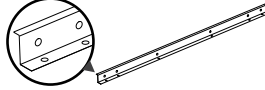
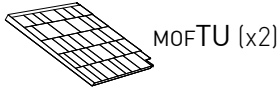

40



MOFTD (x1)

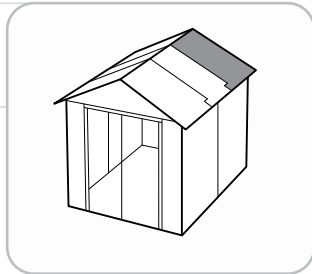

1

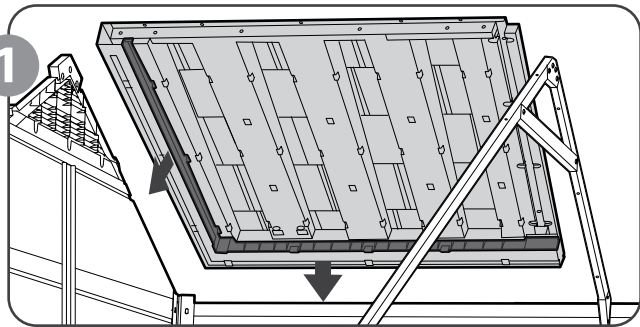

2

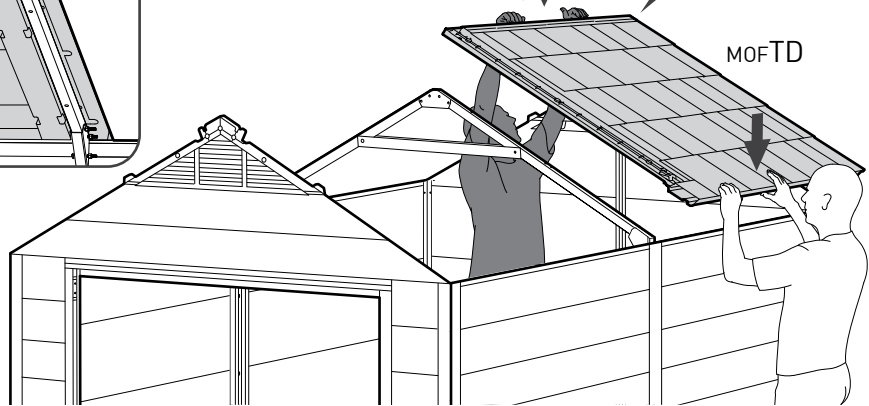
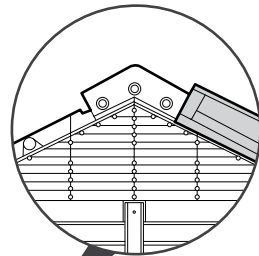
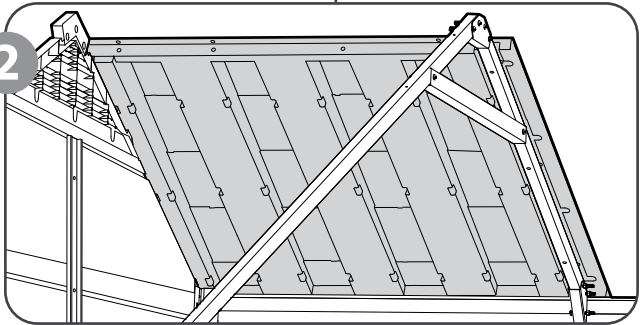

41



MOFT9 (x1)

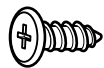

sc15 (x1)

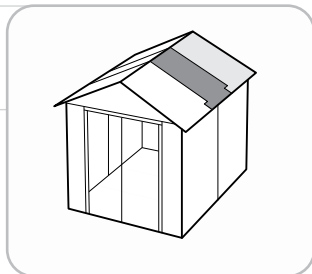

1

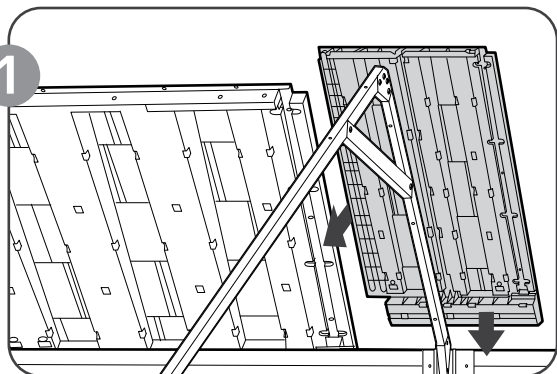

2

